



INSTALLATION
INSTRUCTIONS

EN

MANUALE
D'INSTALLAZIONE

IT

NOTICE
D'INSTALLATION

FR

INSTALLATIONS-
ANLEITUNGEN

DE

INSTRUCCIONES
DE INSTALACIÓN

ES

INSTRUÇÕES DE
INSTALAÇÃO

PT

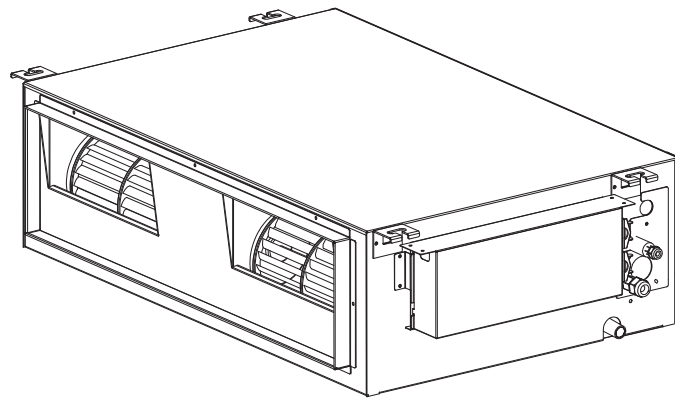

ADIAS19DC
ADIBS13DC
ADICS13DC

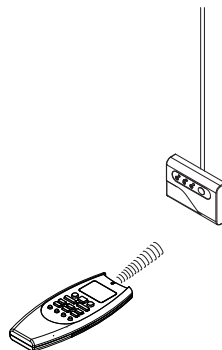

Split air conditioner system

Condizionatore d'aria split system

Climatiseurs split

Zweirohrsystem-Klimaanlage

Acondicionador de aire Split System

Sistema de ar condicionado de Unidades Separadas

- 1 - Installation site selection.....4
- 2 - System wiring diagram4
- 3 - Wires’ length, size and delayed fuse.....4
- 4 - Additional material required for installation (not supplied)5
- 5 - Operating limits.....5
- 6 - Accessories supplied with the unit.....5
- 7 - Tools required for installation (not supplied)5
- 8 - Dimensions, weight and refrigerant connections6
- 9 - Installation procedure7
- 10 - Duct for fresh air9
- 11 - Remote control unit installation10
- 12 - Infrared receiver installation.....10
- 13 - Home automation wiring.....11
- 14 - Default setting reset.....11
- 15 - Pump Down12
- 16 - Test of the system and control of the air volume to the outlet grilles ..12
- 17 - Outdoor/indoor unit refrigerant circuit address.....13
- 18 - Match between remote controller and indoor unit.....16
- 19 - Remote controller: how to change from infrared to wires17
- 20 - Electrical wiring diagram.....18

IMPORTANT!

Please read before installation

This air conditioning system meets strict safety and operating standards.

For the installer or service person, it is important to install or service the system so that it operates safely and efficiently.

operation, you must:

- Carefully read this instruction booklet before beginning.
- Follow each installation or repair step exactly as shown.
- Observe all local, state and national electrical codes.
- Pay close attention to all warning and caution notices given in this manual.
- The unit must be supplied with a dedicated electrical line.



WARNING

This symbol refers to a hazard or unsafe practice which can result in severe personal injury or death.



CAUTION

This symbol refers to a hazard or unsafe practice which can result in personal injury or product or property damage.

Recommendations

- The personnel responsible for receiving the unit must conduct a visual inspection in order to identify all damage to which the unit may have been subjected during transport: refrigerating circuit, electrical cabinet, chassis and cabinet.

If necessary, get help

These instructions are all you need for most installation sites and maintenance conditions.

If you require help for a special problem, contact our sale/service outlet or your certified dealer for additional instructions.

In case of improper installation

The manufacturer shall in no way be responsible for improper installation or maintenance service, including failure to follow the instructions in this document.

SPECIAL PRECAUTIONS

- During installation, connect before the refrigerant system and then the wiring one; proceed in the reverse order when removing the units.

**WARNING****When wiring**

ELECTRICAL SHOCK CAN CAUSE SEVERE PERSONAL INJURY OR DEATH. ONLY A QUALIFIED, EXPERIENCED ELECTRICIANS SHOULD ATTEMPT TO WIRE THIS SYSTEM.

- Do not supply power to the unit until all wiring and tubing are completed or reconnected and checked, to ensure the grounding.
- Highly dangerous electrical voltages are used in this system. Carefully refer to the wiring diagram and these instructions when wiring.
Improper connections and inadequate grounding can cause **accidental injury and death**.
- **Ground the unit** following local electrical codes.
- The Yellow/Green wire cannot be used for any connection different from the ground connection.
- Connect all wiring tightly. Loose wiring may cause overheating at connection points and a possible fire hazard.
- Do not allow wiring to touch the refrigerant tubing or any moving parts of the fan
- Do not use multi-core cable when wiring the power supply and control lines. Use separate cables for each type of line.

When transporting

Be careful when picking up and moving the indoor and outdoor units. Get a partner to help, and bend your knees when lifting to reduce strain on your back. Sharp edges or thin aluminium fins on the air conditioner can cut your fingers.

When installing...**... In a ceiling**

Make sure the ceiling is strong enough to hold the unit-weight. It may be necessary to build a strong wooden or metal frame to provide added support.

... In a room

Properly insulate any tubing run inside a room to prevent "sweating", which can cause dripping and water damage to walls and floors.

When connecting refrigerant tubing

- Keep all tubing runs as short as possible.
- Use the flare method for connecting tubing.
- Apply refrigerant lubricant to the matching surfaces of the flare and union tubes before connecting them; screw by hand and then tighten the nut with a torque wrench for a leak-free connection.
- Check carefully for leaks before starting the test run.

NOTE:

Depending on the system type, liquid and gas lines may be either narrow or wide. Therefore, to avoid confusion, the refrigerant tubing for your particular model is specified as narrow tube for liquid, wide tube for gas.

When servicing

- Turn the power OFF at the main power board before opening the unit to check or repair electrical parts and wiring.
- Keep your fingers and clothing away from any moving parts.
- Clean up the site after the work, remembering to check that no metal scraps or bits of wiring have been left inside the unit being serviced.
- Ventilate the room during the installation or testing the refrigeration system; make sure that, after the installation, no gas leaks are present, because this could produce toxic gas and dangerous if in contact with flames or heat-sources.

REGULATION (EU) No. 517/2014 - F-GAS

The unit contains R410A, a fluorinated greenhouse gas with a global warming potential (GWP) of 2087.50. Do not release R410A into the atmosphere.

Model Combinations:

SEE CATALOGUE

Power Supply:

220 - 240 V ~ 50 Hz

1 - INSTALLATION SITE SELECTION

AVOID

- Direct sunlight.
- Nearby heat sources that may affect unit performance.
- Areas where leakage of flammable gas may be expected.
- Locations where large amounts of oil mist may occur (such as in kitchen or near factory equipment) because oil contamination can cause operation problems and may deform plastic surfaces and parts of the unit.
- Unsteady locations that will cause noise or possible water leakage.
- Locations where the indoor unit and the remote control unit will be splashed with water or affected by dampness or humidity.
- To make holes in areas where electrical wiring or conduits are located

DO

- Select an appropriate position from which every corner of the room can be uniformly cooled.
- Select a sufficiently strong location to support the weight of the unit.
- Select a location where tubing and drain hose have the shortest run to the outside.
- Allow access for operation and maintenance as well as unrestricted air flow around the unit.

2 - SYSTEM WIRING DIAGRAM

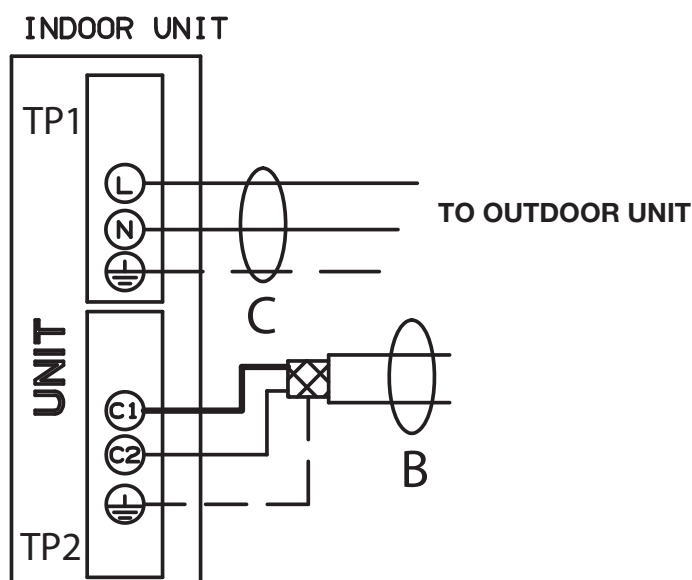

3 - WIRES' LENGTH, SIZE AND DELAYED FUSE

SEE INSTALLATION INSTRUCTIONS OF OUTDOOR UNIT

Connecting wire B (SHIELDED):

Bipolar electric shielded wire; size and length of the suggested electric wire are showed on table "electrical data" (Outdoor unit). The wires have not to be lighter than Mod. H05VVC4V5-K (according to CEI 20-20 CENELEC HD21).

Connecting wire C (with ground conductor):

Multipolar electric wire; size and length of the suggested electric wire are showed on table "electrical data" (Outdoor unit). The wires have not to be lighter than Mod. H07RN-F (according to CEI 20-19 CENELEC HD22). Make sure the length of the conductors between the fixing point and the terminals allows the straining of the conductors L, N before that of the grounding.

4 - ADDITIONAL MATERIAL REQUIRED FOR INSTALLATION (NOT SUPPLIED)

- Deoxidized annealed copper tube for refrigerant tubing connecting the units of the system; it has to be insulated with foamed polyethylene (min. thickness 8mm). For tubing dimensions, tubing length and elevation difference limits, see installation manual of outdoor unit.

MODEL	NARROW TUBE		LARGE TUBE	
	OUTER DIAMETER	MIN. THICKNESS	OUTER DIAMETER	MIN. THICKNESS
ADIAS19	6,35 mm	0,8 mm	9,52 mm	0,8 mm
AWIB-CS13	6,35 mm	0,8 mm	12,7 mm	0,8 mm

- PVC pipe for condensate drain pipe (ø int.18mm) in length suitable to let the condensate flow into the outside drainage.
- Anti-freeze oil for flare connections (about 30g.).
- Electric wire: use insulated copper wires of size and length as shown in the paragraph "WIRING DIAGRAMS" (Outdoor unit).

5 - OPERATING LIMITS

<ul style="list-style-type: none"> ■ Cooling Maximum conditions Outdoor temperature : 43°C D.B. Room temperature : 32°C D.B. / 23°C W.B. 	<ul style="list-style-type: none"> ■ Heating Maximum conditions Outdoor temperature : 24°C D.B. / 18°C W.B. Room temperature : 27°C D.B.
<ul style="list-style-type: none"> ■ Cooling Minimum conditions Outdoor temperature : -15°C D.B. Room temperature : 10°C D.B. / 6°C W.B. 	<ul style="list-style-type: none"> ■ Heating Minimum conditions Outdoor temperature : -15°C D.B. Room temperature : 5°C D.B.

6 - ACCESSORIES SUPPLIED WITH THE UNIT

The following accessories are supplied with the unit:

- Remote control unit.
- Batteries for remote control unit.
- Receiver assembly.

7 - TOOLS REQUIRED FOR INSTALLATION (NOT SUPPLIED)

1.Standard screwdriver	7.Hacksaw	12.Tube flaring tool
2.Phillips head screwdriver	8.Core bits ø 8	13.Torque wrench
3.Knife or wire stripper	9.Hammer	14.Adjustable wrench
4.Tape measure	10.Drill	15.Reamer (for reburrring)
5.Level	11.Tube cutter	16.Hex. key
6.Sabre saw or key hole saw		

8 - DIMENSIONS, WEIGHT AND REFRIGERANT CONNECTIONS

MODEL	A (mm)	B (mm)	C (mm)	D (mm)	E (mm)
ADIA	900	780	782	801	457 x 1
ADIB-C	1106	986	988	962	290 X 2

MODEL	WEIGHT (kg)
ADIA	30
ADIB	35
AWIC	35

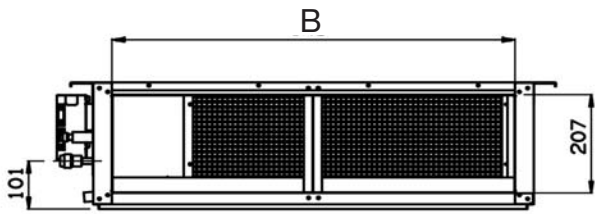

REAR VIEW

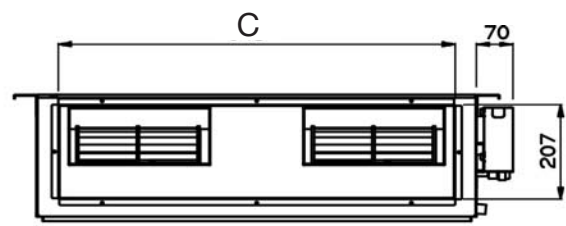

FRONT VIEW

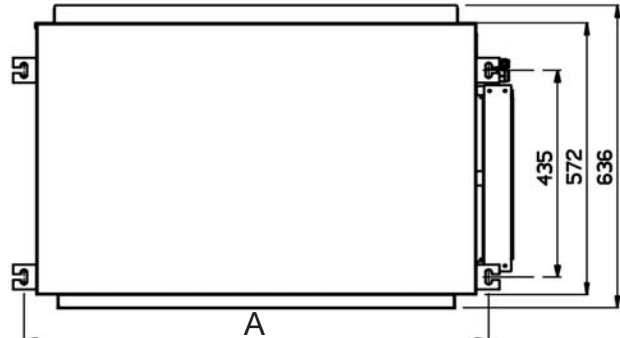

TOP VIEW

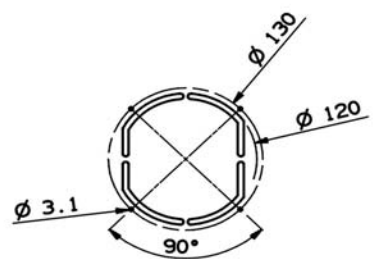

FRESH AIR INTAKE PORT

CONVOGLIATORE ARIA
(ACCESSORIO SU RICHIESTA)

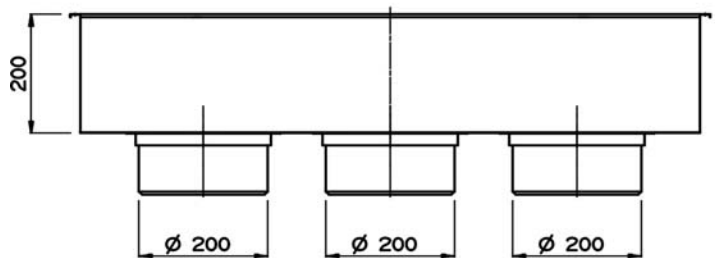
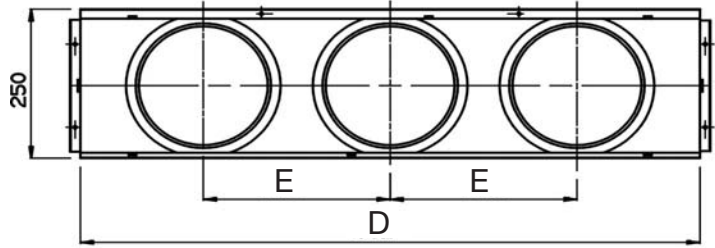

REFRIGERANT TUBING SIDE

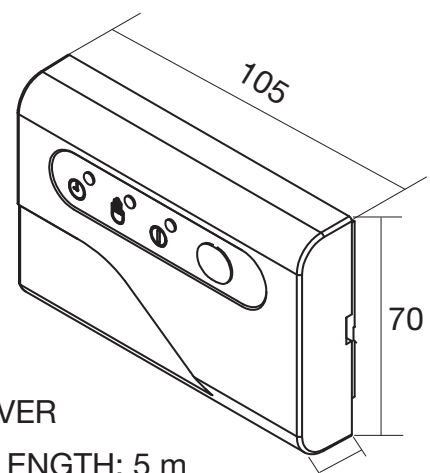
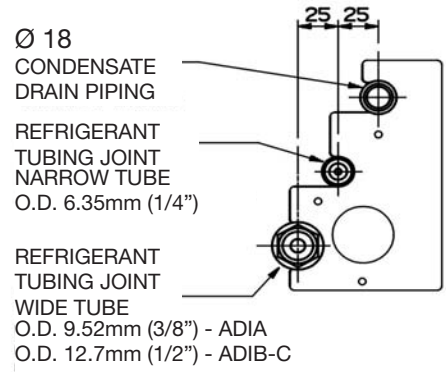

RECEIVER
WIRE LENGTH: 5 m

9 - INSTALLATION PROCEDURE

EN

- A** Minimum operation and maintenance area.

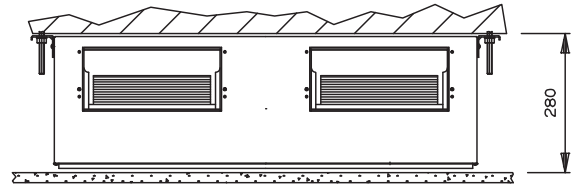
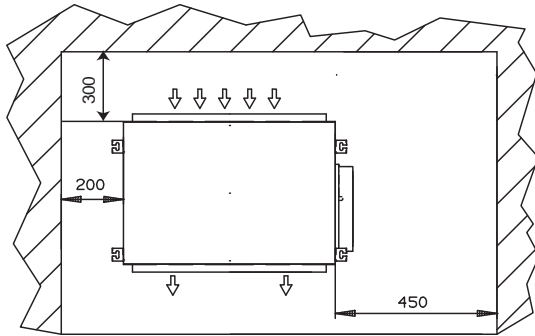

- B** Find the space for the installation of the return air grille and mark the opening to do. Cut the false ceiling.

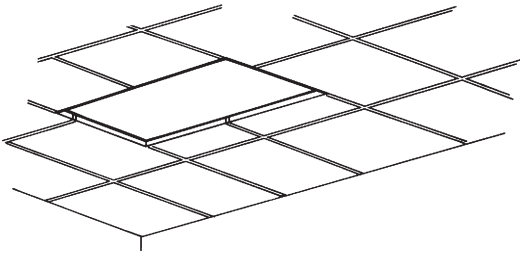

- C** Use rawl plug suitable to the ceiling consistence and four M10 threaded bars of suitable lenght (not supplied).

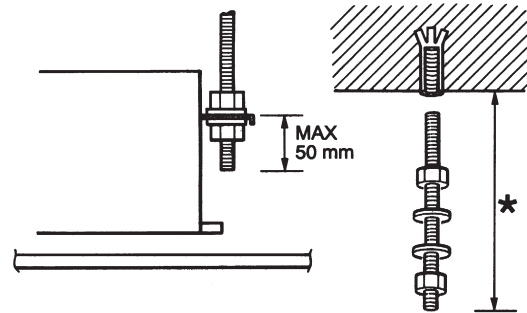

- D** Mark on the ceiling the holes for the hanging rods, verify the distance of the centres.

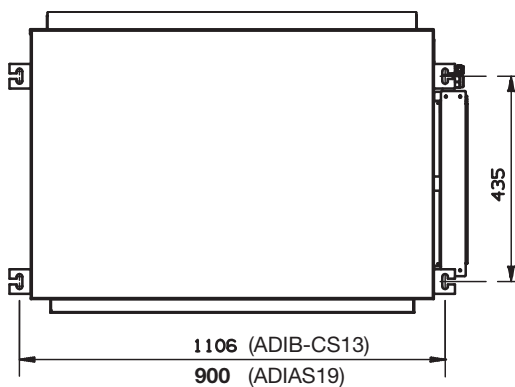

- E** Drill a 65/80 mm diameter hole, for the passage of refrigeration pipework, condensate pipework and electrical cable. Insert a PVC pipe in the wall.

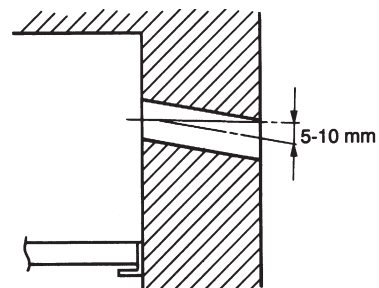

F Secure the unit in position with locknuts and washers, level the unit, keeping the right distance from the falseceiling for the installation of return air grille.

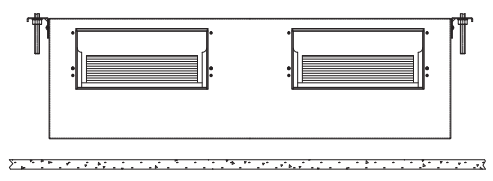

G Predispose a removable panel of the falseceiling for servicing.

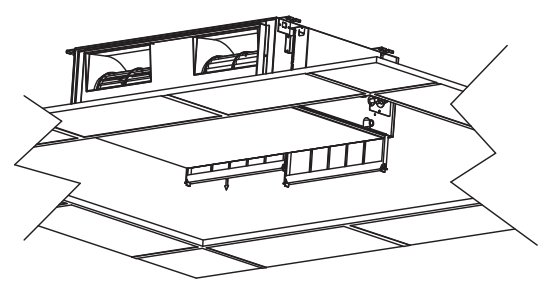

H The unit is supplied of PVC hose from the condensate pump. Maximum pump lift is 250 mm over the unit. Convey the condensate with a positive slop (min. 1:100) to the outside. The highest point in the condensate pipework should be as close to the unit as possible. This prevents a large volume of water draining back into the unit when it is switched off.

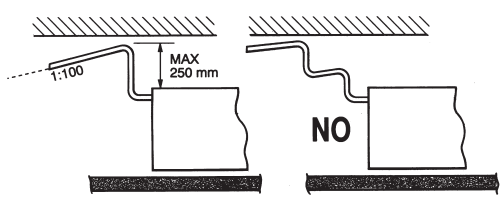

I Convey the condensate to the outside with a positive slope, from a trap at the end if necessary.

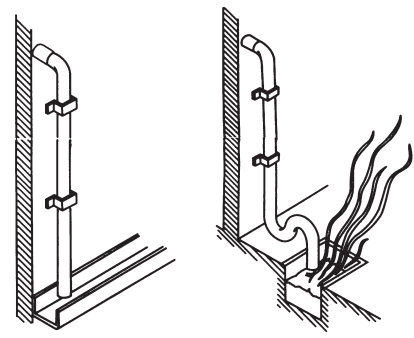

J Predispose the terminals of the wire to connect to the terminal strip and connect them. (See electric wiring to connect).
Secure inter-unit wire using the supplied clamp.



Loose wiring may cause the terminal to overheat or result in unit malfunction. A fire hazard may also exist. Therefore, be sure all wiring is tightly connected. When closing the electrical component box, take care not to leave part of the wires out or let them get caught between the lid and the unit. Check to see that the tab is aligned, then tighten the screw.

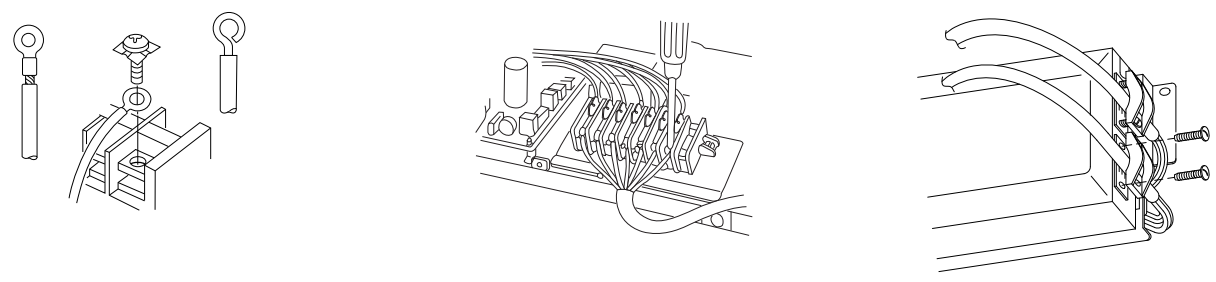

K On the front and rear side of the unit a rectangular port (with flange) helps during duct mounting.

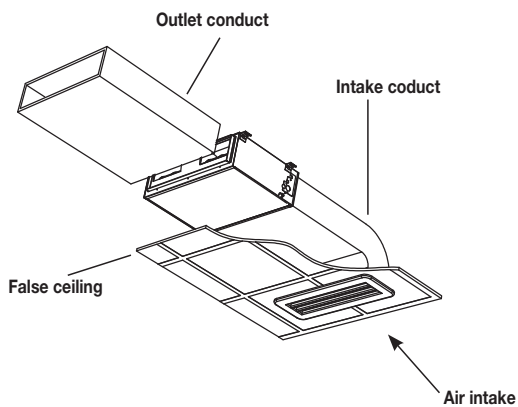

L Rear and front flange for the air intake.

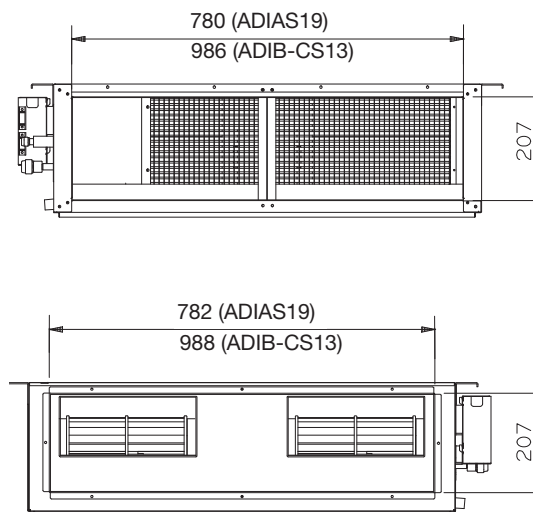

M Discharge air duct (optional accessory).

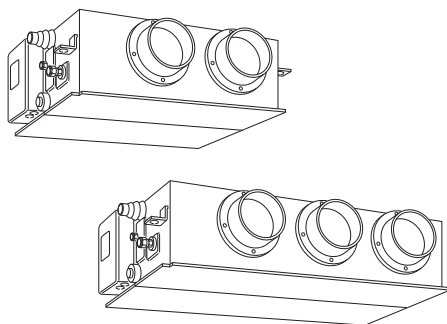

N Remove the filter and pour, inside the condensate drain pan, 0.5 liter of water. Start the unit checking for proper drain pump operation.

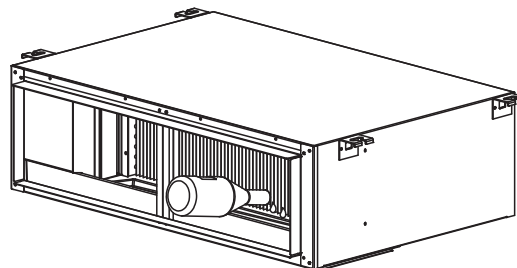

10 - DUCT FOR FRESH AIR

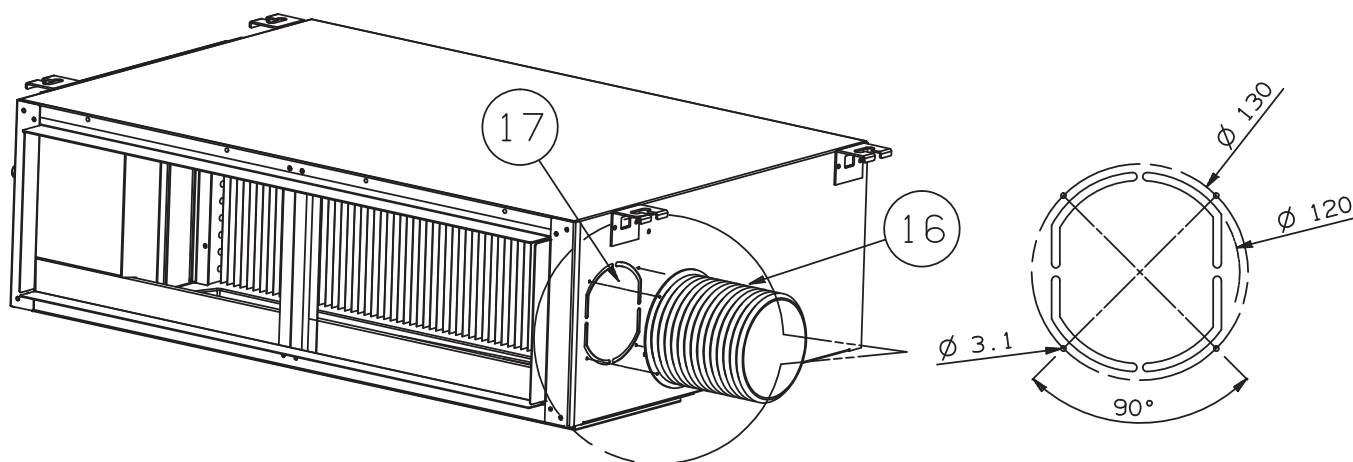

There is a duct connection port ⑯ for drawing in fresh air.

The supplementary fan motor for outside air intake has to be supplied separately and controlled by a bipolar ON-OFF switch with safety fuses.

Fresh air flow must be about 10% of the total air flow to avoid operating problems and noise.

- Open the knock-out hole ⑰, fix a Ø 120 mm flange on the unit and connect the thermally insulated duct.
- Install an outside grille with filter inspection port to prevent dust and leaves from entering and fouling the indoor unit heat exchanger.

11 - REMOTE CONTROL UNIT INSTALLATION

To ensure that the air conditioner operates correctly, DO NOT install the remote control unit in the following places:

- In direct sunlight.
- Behind a curtain or other places where it is covered.
- More than 8 m away from the air conditioner.
- In the path of the air conditioner's airstream.
- Where it may become extremely hot or cold.
- Where it may be subject to electrical or magnetic noise.
- Where there is an obstacle between the remote control unit and the air conditioner.

WALL-MOUNTED POSITION

- Momentarily place the remote control unit in the desired mounting position.
- Verify that the remote control unit can operate from this position.
- Fix the support at the wall with two screws and hang the remote control unit.

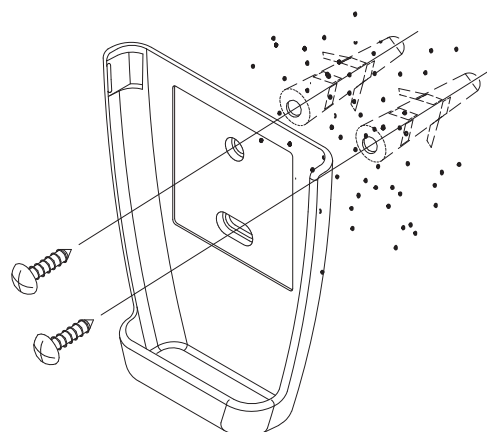

12 - INFRARED RECEIVER INSTALLATION

- A** Slot a screwdriver by the 2 slits on the cover sides, and separate the cover from the base.

Do not lay the receiver cable near any power lines, and do not put it into any raceways or metal tubes together with other power lines. Install the receiver far from electromagnetic interferences. Always provide for an earth connection near the receiver location, where possible.

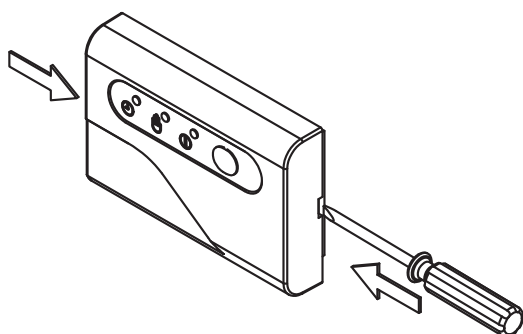

- B** If allowed by the local electric-power standards, standard electric-component boxes can be used for assembling the receiver.

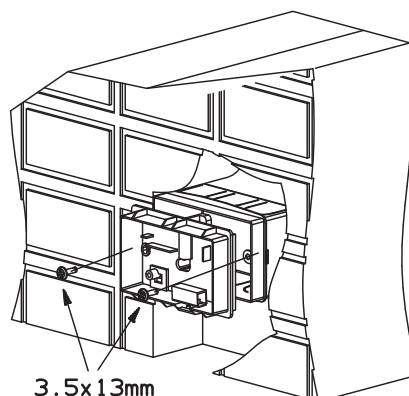

- C** Perform the earth connection with the terminal on the base, as provided. Complete earth connection and fasten the other end of the cable to the terminal 3 (COM) TP1 in the electric panel.

Do not power the system up, and do not start the unit before having completed the refrigerant piping and the electric installation.

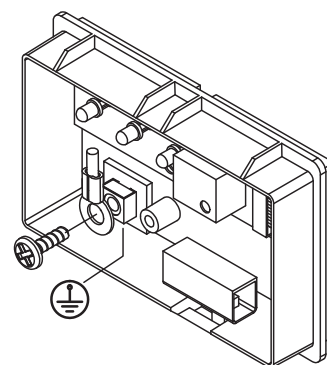
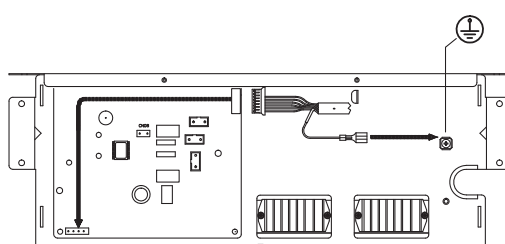
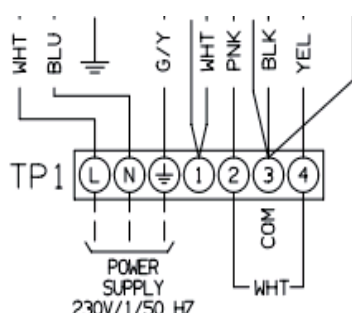

D End of installation.

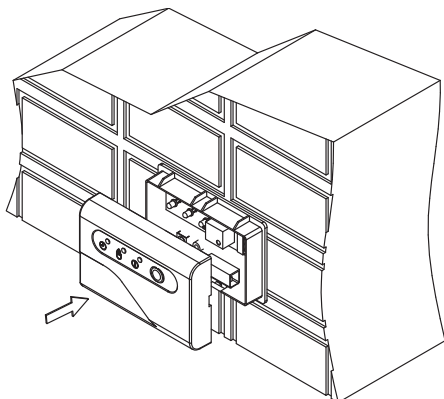

13 - HOME AUTOMATION WIRING

It is possible to connect the unit to a Home Automation system, according to the following instructions:

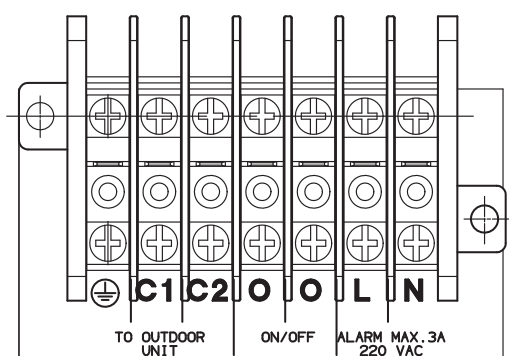

ON/OFF (Terminals O O) - DEFAULT FACTORY STATE: CLOSED

Contact open: the unit does not operate (always OFF) - inputs from the remote control unit are not processed.

Contact closed: the unit operates in the normal way, according to the inputs coming from the remote control unit.

ALARM (Terminals L N) :

These terminals are connected to the contact (normally open) of a power relay (220 VAC, MAX 3A) that is activated every time any alarm occurs on the unit.

When an alarm occurs, the poles of the terminal block will have a voltage of 220V - 50Hz Max. electric load: 3A - 240V

14 - DEFAULT SETTING RESET

To operate the unit again with the default setting it is necessary to set the remote control as follows:

Filter: ON

Night Mode / High Power Mode: OFF

Operation mode: AUTO

Flap: AUTO

Set-point: 10°C

At this point, press contemporary the FAN and IFEEL keys of the remote control for more than 5 seconds and release them by pointing the remote control towards the indoor unit.

If the setting is correct you will hear an acoustic signal as confirmation (4 beep).

After the acoustic signal it is necessary to switch OFF and ON the air conditioner to enable the real reset of the setting. Now the unit starts again operating with the factory setting.

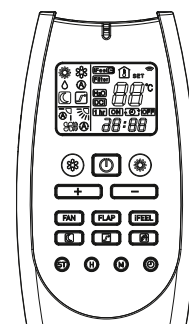

15 - PUMP DOWN (See Installation Instruction of Outdoor Unit)

Pump down means collecting all refrigerant gas in the system back into the outdoor unit without losing gas. Pump down is used when the unit is to be moved or before servicing the refrigerant circuit.

16 - TEST OF THE SYSTEM AND CONTROL OF THE AIR VOLUME TO THE OUTLET GRILLES

The unit is prearranged to supply an external static pressure of about 5 mm. Too high resistances in the air distribution system can cause an exceedingly small air volume to the outlet grilles. This trouble can be solved by increasing the fan speed as follows:

- A** Open the cover of the electrical junction box. Take out JP2.

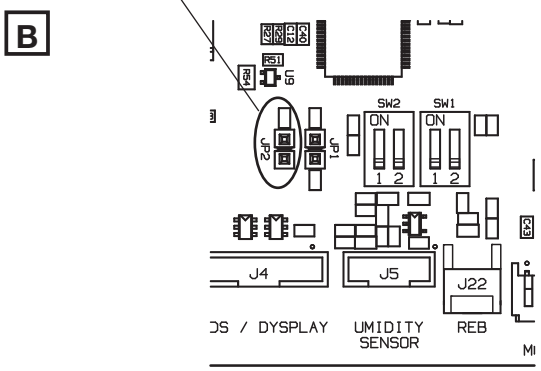
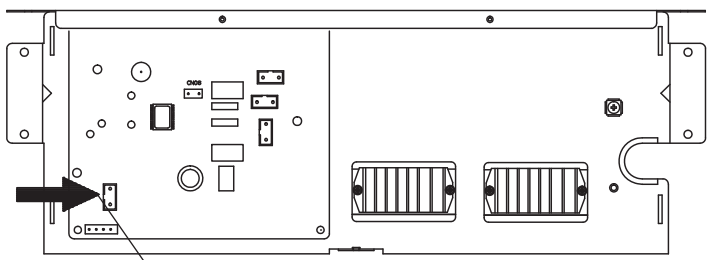

With the contact JP2 open, the external static pressure will increase to about 7 mm. Check static pressure and air flow rate on the fan performance graph.

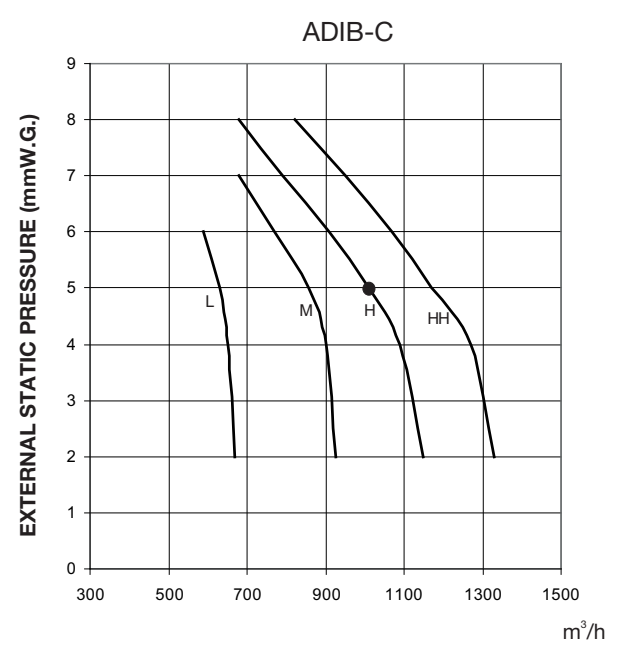
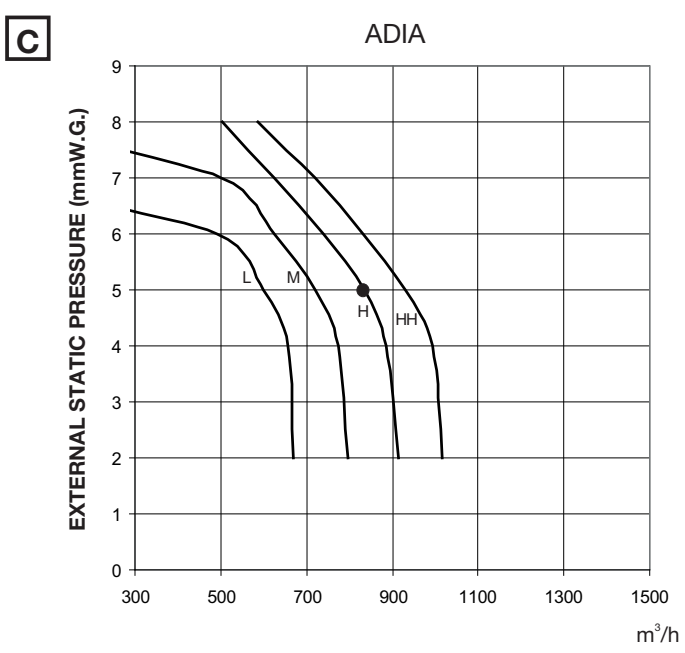

L = Low fan speed
 M = Middle fan speed
 H = High fan speed
 HH = Very high fan speed

- **H:** Standard supplied unit. Available fan speeds: Low-Middle-High (L - M - H). Max. static pressure: about 50 Pa
- HH:** JP2 disconnected. Available fan speeds: Middle-High-Very high (M - H - HH). Max. static pressure: about 62 Pa.

Indoor units that are part of a multisplit system must be properly configured to be able to communicate with the outdoor unit over different channels (Indoor A, Indoor B, etc...) of the communication bus.

Each indoor unit address must correspond to the physical connection of the indoor unit to the outdoor unit refrigerant circuit, i.e.:

Refrigerant Circuit A <--> Indoor Unit Address A

Refrigerant Circuit B <--> Indoor Unit Address B

...

There are three methods to set the address of an indoor unit:

- (1) **Dip-switch setting:** the address is set by mean of a dip-switch located on the indoor unit pcb.
- (2) **Remote controller procedure:** the address is set by mean of a special setting on the remote controller.
- (3) **Automatic addressing procedure:** the address is automatically set on every indoor unit of the system by mean of an automatic procedure.

(1) ADDRESS SETTING THROUGH DIP-SWITCHES (UP TO 4 INDOOR UNITS)



Disconnect the power

Check that the setting of switch SW2 (PCB) corresponds to the figure:



(2) ADDRESS SETTING THROUGH REMOTE CONTROLLER (UP TO 8 INDOOR UNITS)

Set the remote controller as shown in the table.

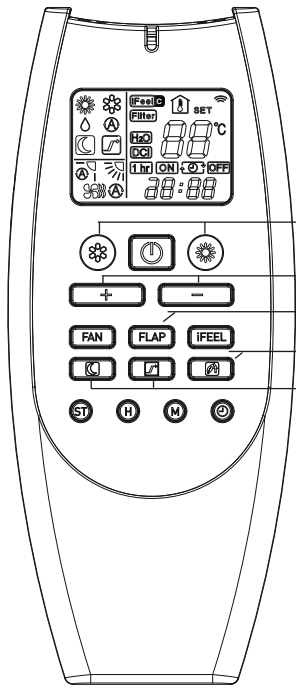

BUTTON	SETTING
working mode (COOL - HEAT)	AUTO
set point	—
flap	AUTO
filter	ON
night mode / high mode	OFF
ifeel	Any
Fan	Any

- Indoor unit **A**: 11°C
- Indoor unit **B**: 12°C
- Indoor unit **C**: 13°C
- Indoor unit **D**: 14°C
- Indoor unit **E**: 15°C
- Indoor unit **F**: 16°C
- Indoor unit **G**: 17°C
- Indoor unit **H**: 18°C

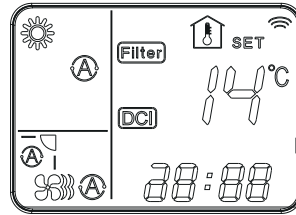
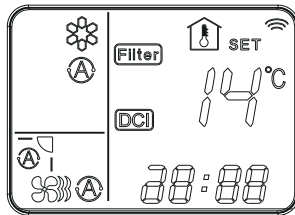

At this point, press together FAN + IFEEL buttons for more than 7 seconds and release them pointing the remote controller to the indoor unit receiver. Be sure to send the signal to only one indoor unit and that there is no other indoor unit that could receive the same signal. If the signal is received, the indoor unit will emit 5 consecutive beeps.

NOTE: for electrical connections, refrigerant circuit connection and check, consult the Installation Instruction of outdoor unit.

(3) AUTOMATIC ADDRESSING PROCEDURE

System requirements:

Outdoor unit must have a recent firmware version that supports the automatic addressing procedure.
 Indoor units must have a recent firmware version that supports the automatic addressing procedure
 Dip-switch for communication address setting on the indoor unit (SW2) must be left to the factory default state, i.e. to the OFF position.

Activation of automatic addressing procedure

Power on the whole system.
 Verify that there is no error on the indoor units, but the error "Address not set" (see Auto-diagnosis table).
 Switch on the remote controller of any of the indoor units of the system and set it as follows:

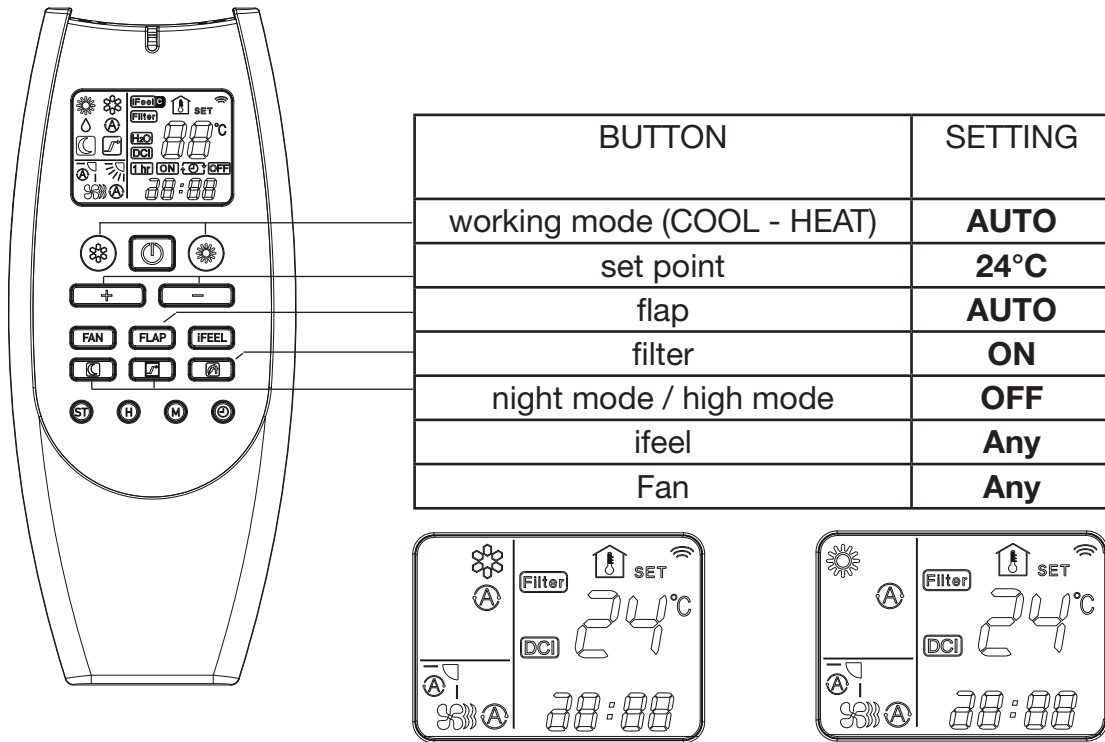

BUTTON	SETTING
working mode (COOL - HEAT)	AUTO
set point	24°C
flap	AUTO
filter	ON
night mode / high mode	OFF
ifeel	Any
Fan	Any

Press together FAN + IFEEL buttons for more than 7 seconds and release them pointing the remote controller to the indoor unit receiver. Be sure to send the signal to only one indoor unit and that there is no other indoor unit that could receive the same signal.

If the signal is received, the indoor unit will emit 5 consecutive beeps.

After some seconds, every indoor unit will show the following LED combination to confirm that the automatic addressing procedure has been activated.

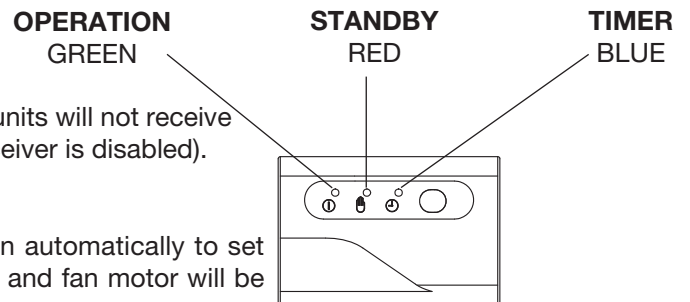

From this moment until the end of the procedure the indoor units will not receive anymore the signals from the remote controllers (infrared receiver is disabled).

Execution of automatic addressing procedure

Once the procedure has been activated, the system will run automatically to set the address of every indoor unit. In this period, compressor and fan motor will be activated.

Once activated, the procedure takes about 4-5 minutes per outdoor unit circuit to be completed. This time doesn't depend on the number of indoor units actually connected to the outdoor unit, but on the number of refrigerant circuits of the outdoor unit.

End of automatic addressing procedure

When all the circuits have been tested and the address of every indoor unit has been set, the outdoor unit will stop and every indoor unit will switch off (standby mode).

In any case (procedure successful or failed) the infrared receiver of every indoor unit will be re-activated.

If there is no error on the indoor units, the system is ready to be used.

If there is the error "Address not set" (see Auto-diagnosis table) on any indoor unit, re-run the automatic addressing procedure or manually set the address on that indoor unit with the dip-switch or with the remote controller.

18 - MATCH BETWEEN REMOTE CONTROLLER AND INDOOR UNIT

- Disconnect the power of indoor unit.
- Remove the batteries from the remote control unit.
- Set the microswitches (see table).
- Insert the batteries in the remote control unit.
- Switch on the indoor unit.

At this point the system starts operating with the new address.

Set SW1 (PCB) as shown in the table.

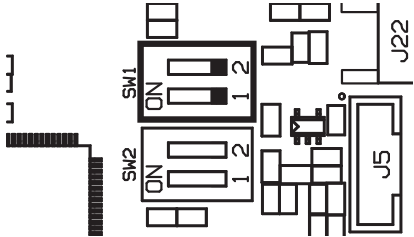
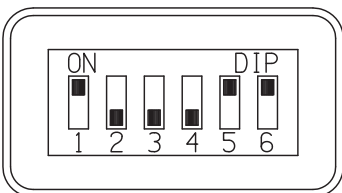
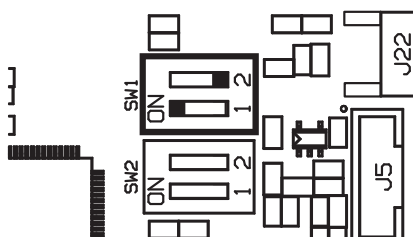
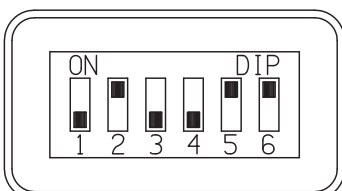
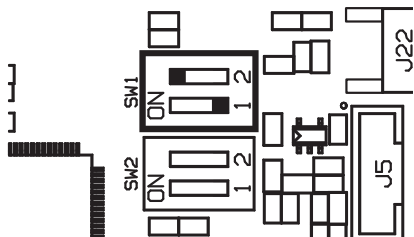
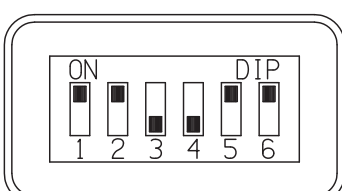
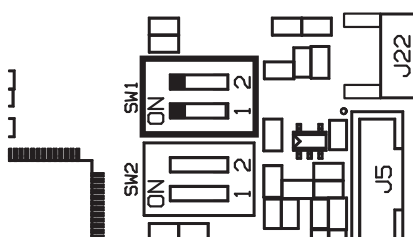
INDOOR UNIT	REMOTE CONTROLLER	PCB
<p>1</p> <p>FACTORY STATE</p>	 <p>1=OFF 2=OFF 3= OFF 4=OFF 5=ON 6=ON</p>	 <p>SW1: 1=OFF 2=OFF</p>
<p>2</p>	 <p>1=ON 2=OFF 3=OFF 4=OFF 5=ON 6=ON</p>	 <p>SW1: 1=ON 2=OFF</p>
<p>3</p>	 <p>1=OFF 2=ON 3=OFF 4=OFF 5=ON 6=ON</p>	 <p>SW1: 1=OFF 2=ON</p>
<p>4</p>	 <p>1=ON 2=ON 3=OFF 4=OFF 5=ON 6=ON</p>	 <p>SW1: 1=ON 2=ON</p>

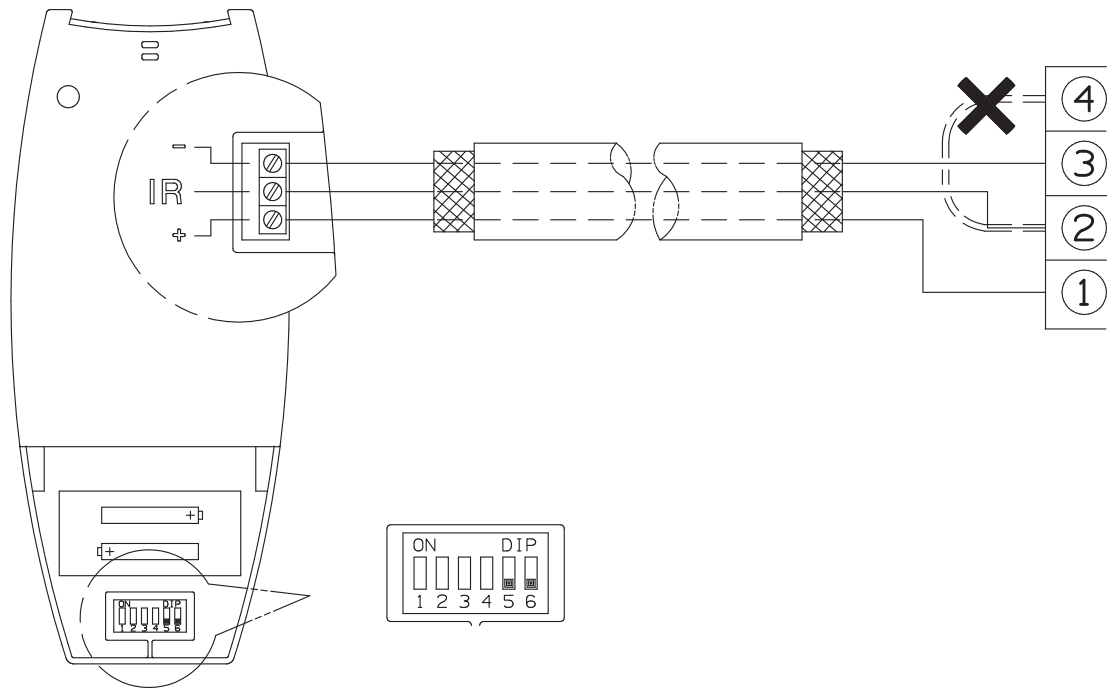

PREPARE THE REMOTE CONTROLLER

- Detach the plastic cover of the remote controller terminal block.
- Open the batteries compartment, remove the batteries and set microswitches 5 and 6 in OFF position.
- Close the compartment without replacing the batteries (remote controller will be powered by wire).

CONNECTION

Use a tripolar electric shielded wire 0,5mm², max. length 15m. The wires have not to be lighter than Mod. H05VVC4V5-K (according to CEI 20-20 CENELEC HD21).

CONNECTING THE REMOTE CONTROLLER TO THE 5 POLES TERMINAL BLOCK INSIDE THE ELECTRICAL PANEL, AS FOLLOWS:

- Remove the “bridge” wire between the terminals 2 and 4.
- Connect the terminal 1 to the bottom terminal of remote control terminal block (+ pole).
- Connect the terminal 2 to the medium terminal of remote control terminal block (IR).
- Connect the terminal 3 to the upper terminal of remote control terminal block (- pole).

20 - ELECTRICAL WIRING DIAGRAM - SCHEMA ELETTRICO - SCHÉMA ÉLECTRIQUE - ELEKTRISCHER SCHALTPLAN - ESQUEMA ELÉCTRICO - DIAGRAMA ELÉTRICO

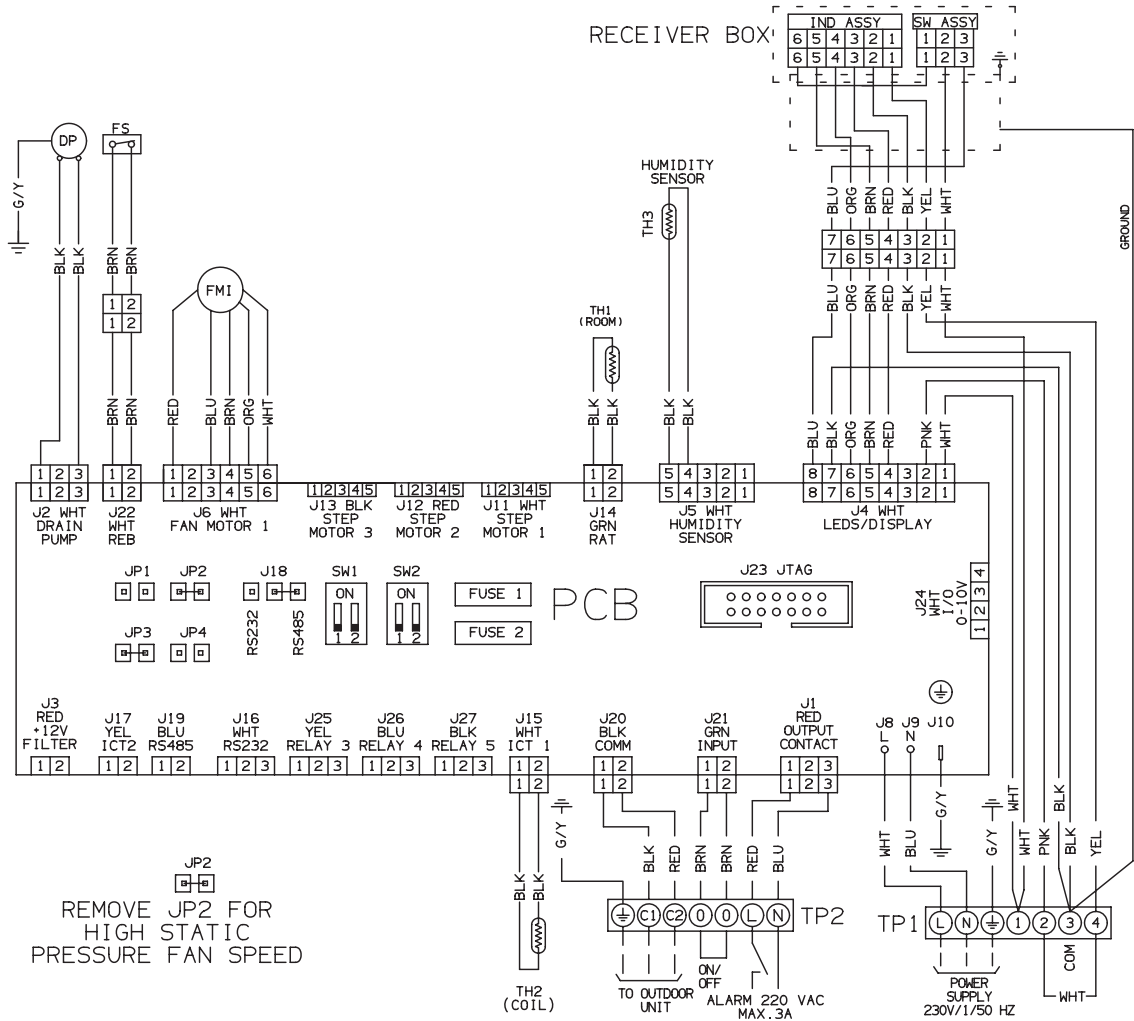

Wires color legend

Legenda colori fili elettrici

Légende des couleurs des fils électriques

Beschriftung der Leitungs-Farben

Leyenda de los colores de los cable electricos

Legenda das côres dos fios elétricos

	EG	I	F	D	E	P
BLK	BLACK	NERO	NOIR	SCHWARZ	NEGRO	PRETO
BLU	BLUE	BLU	BLEU	BLAU	AZUL	AZUL
BRN	BROWN	MARRONE	MARRON	BRAUN	MARRÓN	CASTANHO
G / Y	GREEN / YELLOW	VERDE / GIALLO	VERT / JAUNE	GRÜN / GELB	VERDE / AMARILLO	VERDE / AMARELO
GRY	GREY	GRIGIO	GRIS	GRAU	GRIS	CINZENTO
ORG	ORANGE	ARANCIONE	ORANGE	ORANGE	NARANJA	COR-DE-LARANJA
PNK	PINK	ROSA	ROSE	ROSA	ROSA	COR-DE-ROSA
RED	RED	ROSSO	ROUGE	ROT	ROJO	ENCARNADO
VLT	VIOLET	VIOLA	VIOLET	VIOLETT	VIOLETA	VIOLETA
WHT	WHITE	BIANCO	BLANC	WEISS	BLANCO	BRANCO
YEL	YELLOW	GIALLO	JAUNE	GELB	AMARILLO	AMARELO

argoclima s.p.a.

Via Alfeno Varo, 35 - 25020 Alfianello - BS - Italy

Tel. +39 0331 755111 - Fax +39 0331 755501

www.argoclima.com