

AS DIRECT-EXPANSION INDOOR UNIT CASSETTE MODEL



Code	Model	Size	Description
387006190	ASIAS8DC	A	Cassette with DC Inverter motor - Infrared remote controller - Integrated temperature sensor - Relative humidity sensor
387027154	ASGIDC	-	Grid with temperature and humidity sensor for ASIAS8DC model
387006192	ASICS10DC	C	Cassette with DC Inverter motor - Infrared remote controller - Integrated temperature sensor - Relative humidity sensor
387027155	ASGI25DC	-	Grid temperature and humidity sensor for ASICS10DC model
387006193	ASIDS13DC	D	Cassette with DC Inverter motor - Infrared remote controller - Integrated temperature sensor - Relative humidity sensor
387027156	ASGI48DC	-	Grid temperature and humidity sensor for ASIDS13DC model

Perfect for large to small commercial and public spaces, offices, shops and restaurants. AS is made from insulated metal and consists of a calibrated fan, flaps that can be positioned as desired, a built-in waterspout and air exchange capabilities. The grille is made from high quality plastic



A ASIA S8 DC

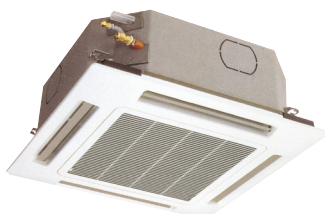

C ASIC S10 DC

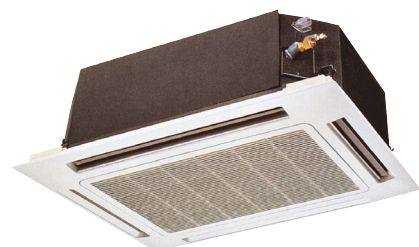

D ASID S13 DC

MODEL		ASIAS8DC	ASICS10DC	ASIDS13DC
Heating/Cooling capacity	kW	up to 3.7/4.0	up to 9.0/11.0	up to 13.0/14.0
Size		A	C	D
Air flow rate (sl.-l.-m.-h.)	m ³ /h	200-530-630-750	850-1060-1160-1300	1200-1700-1980-2300
Dehumidification	l/h	1.2	3.6	3.6
Condensation pump static pressure	mm.c.a.	250	250	250
Fan speed	n°	3 + auto - by remote control	3 + auto - by remote control	3 + auto - by remote control
Sound pressure at 2 m (sl.-l.-m.-h.)	dB(A)	27-43-46-50	38-43-44-46	38-44-48-52
Electrical power supply	V/Ph/Hz	230/1/50-60	230/1/50-60	230/1/50-60
Type of motor		DC Inverter	DC Inverter	DC Inverter
Electrical power input	W	8-24-28-36	13-20-25-41	22-36-43-64
Liquid pipe diameter	mm (inch)	6.35 (1/4")	6.35 (1/4")	6.35 (1/4")
Gas pipe diameter	mm (inch)	9.52 (3/8")	12.7 (1/2")	12.7 (1/2")
Net dimensions (H./W./D.)	mm	296/575/575	310/760/760	338/1050/760
Net dimensions of grille (H./W./D.)	mm	41/730/730	30/860/860	30/1150/860
Net weight	kg	19	22	27
Remote control supplied		Yes	Yes	Yes
Room temperature adjustment range	°C	from +10 to +32	from +10 to +32	from +10 to +32
Relative humidity sensor		Yes	Yes	Yes

AS DIRECT-EXPANSION INDOOR UNIT CASSETTE MODEL

ASIAS8DC unit

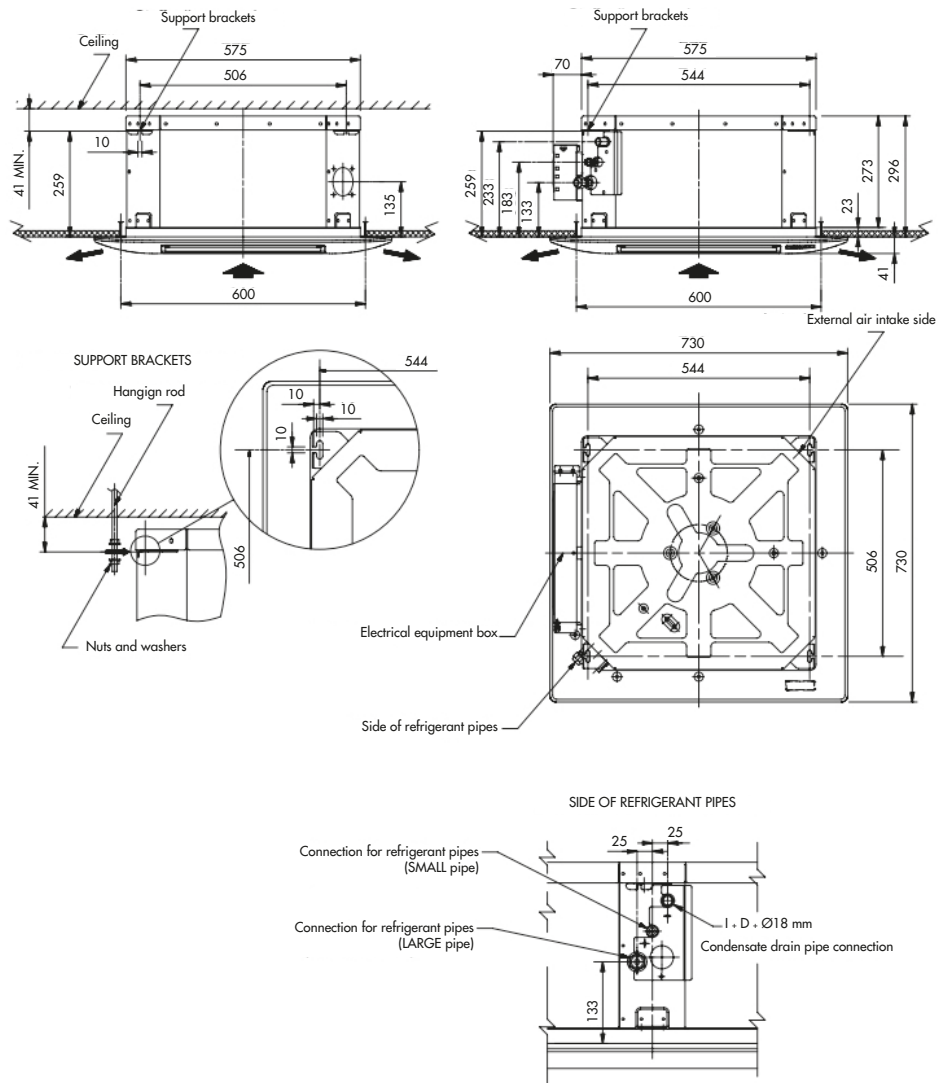

ASICS10DC and ASIDS13DC units

MODEL	L	H	X	Y	Z
ASIC S10	760	310	260	860	500
ASID S13	1050	340	290	1150	750

A Condensation drain pipe hole: external diameter of 32 mm

