



EN

PORTABLE AIR CONDITIONER (LOCAL)

ERIS & ERIS PLUS



SERVICE MANUAL

Read the instructions carefully before operating the appliance or carrying out maintenance work. Observe all the safety instructions; failure to observe the instructions may lead to accidents and/or damage. Store these instructions in a safe place for future reference.

I . Remove filter frame, filter screen

1. hold the two cards above the frame by hand and pull them out.

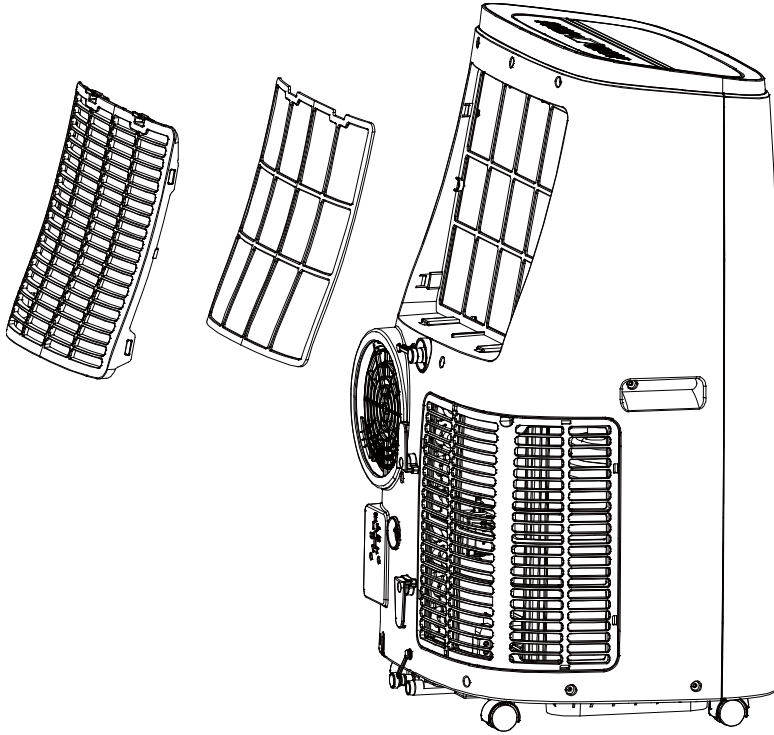

II. Removing back panels

1. first remove the two screws of the left and right handle position with a screwdriver; the upper three screws, the net frame left and right two screws, the middle drain cover side one screw, the heat drain tube side one screw, the lower rear outlet left and right sides altogether six screws

2. slightly lift the back plate handle position with your hand and pull out.

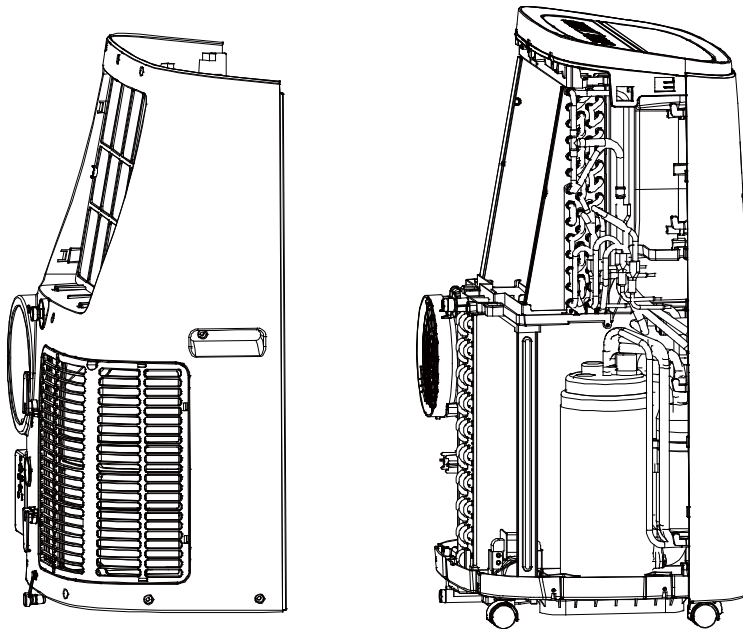
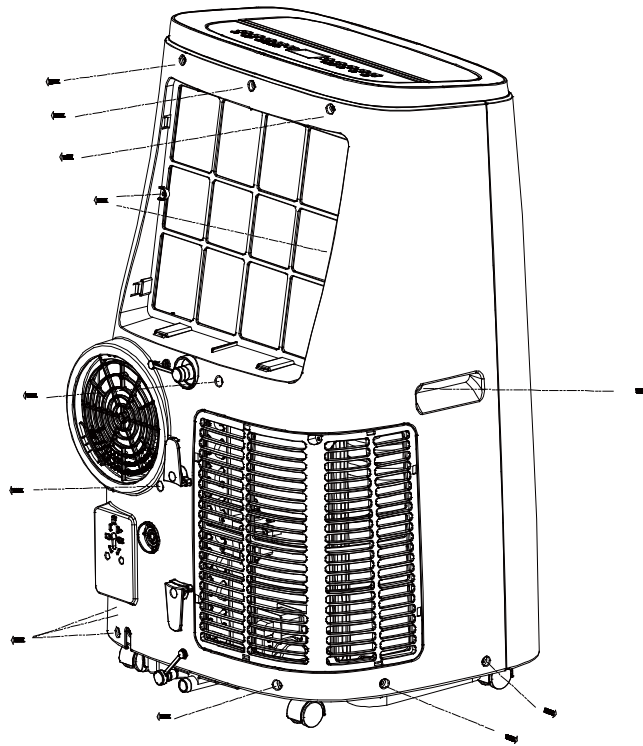

Remove front panel, top cover assembly

1. first remove the bottom three screws with a screwdriver, then remove the two screws behind the top cover assembly, and pull out the connecting terminals of the top cover connection

2. horizontally remove top cover assembly and front panel

3. remove the left and right screws behind the top cover assembly.

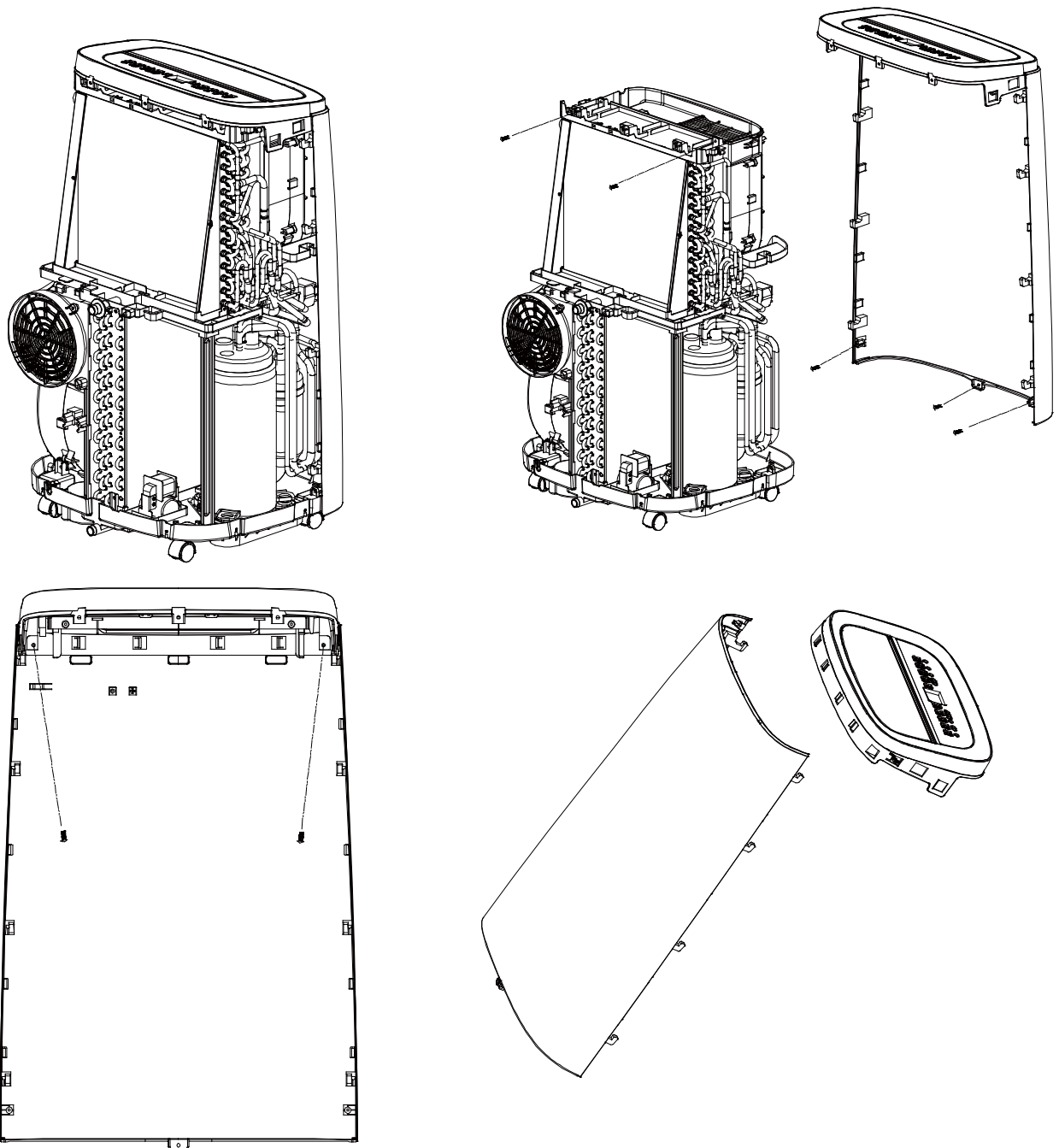

IV. Split top cover, control panel

1. open the outlet swing blade, hold the end of one side of the swing blade, pull out its access to the top cover fixed hole, and then pull out the other end of the swing blade top cover limit.

2. the falling wind blade is drawn from the other end of the top cover fixing hole;

3. pinch the position of the swing blade link and the swing blade link, pull out the connecting rod fastened to the swing blade card position; then pull the other swing blade card position and the connecting rod out.

4. loosen the three screws on the back of the display board and remove the display board; pull out the connected terminal.

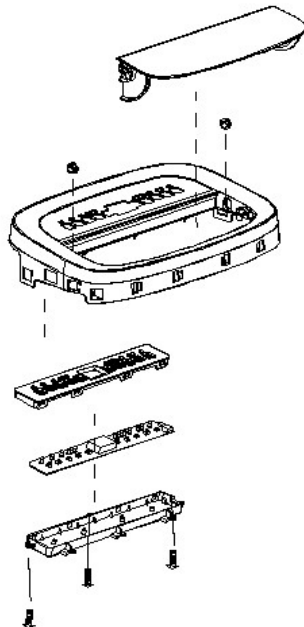

IV. Split top cover, control panel

1. open the outlet swing blade, hold the end of one side of the swing blade, pull out its access to the top cover fixed hole, and then pull out the other end of the swing blade top cover limit.

2. the falling wind blade is drawn from the other end of the top cover fixing hole;

3. pinch the position of the swing blade link and the swing blade link, pull out the connecting rod fastened to the swing blade card position; then pull the other swing blade card position and the connecting rod out.

4. loosen the three screws on the back of the display board and remove the display board; pull out the connected terminal.

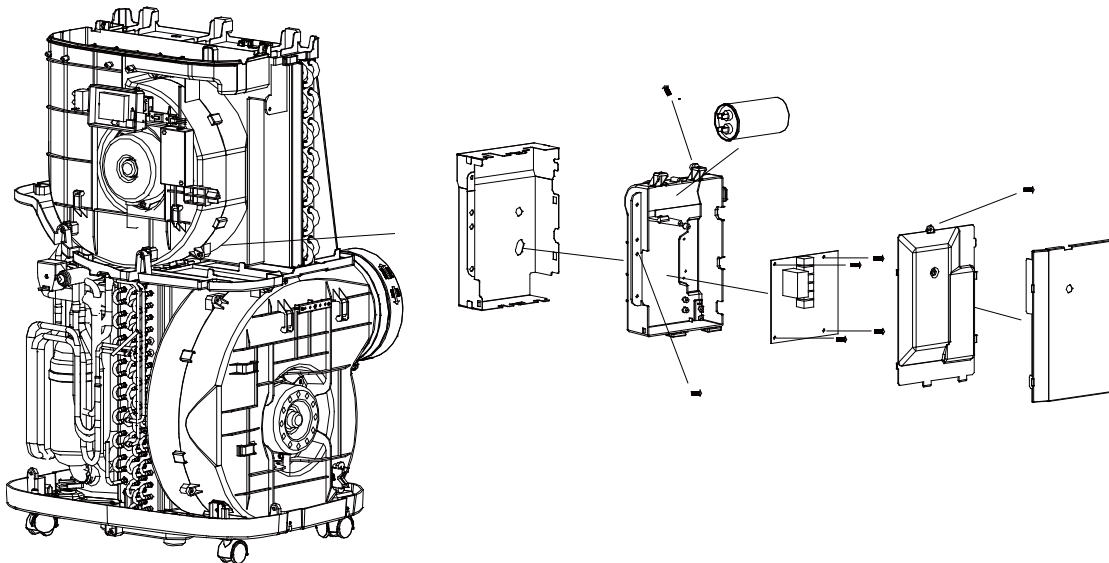

VI. Split air supply duct components

1. remove the two screws connected to the top of the evaporator and the two screws connected to the middle partition, and move out horizontally.

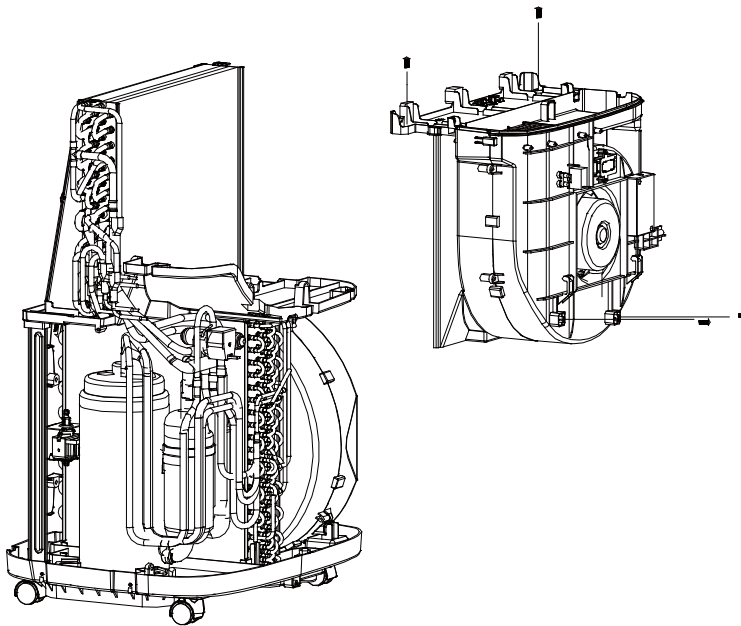

2. remove the WIFI components fixed in the duct volute with two screws and five volute screws.

3. loosen the nut fastened to the motor shaft and remove the wind turbine outward

4. loosen the four screws of the fixed motor and remove the motor.

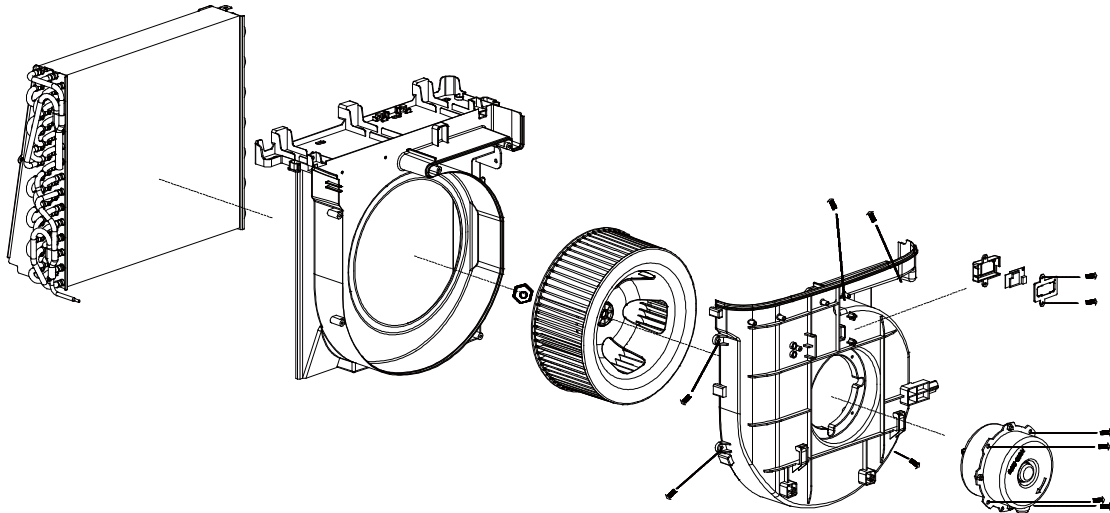

VII. Lower framework component splitting

1. remove 1 screw that connects the partition to the condenser in the front of the air conditioner
2. remove 1 screw left and right between the middle partition and the side of the evaporator, then remove 2 fixed screws connected between the middle partition and the exhaust duct assembly
3. remove 1 screw attached to the condenser in the middle partition behind the air conditioner.
4. remove 1 fixing screw that the middle partition is connected with the main support.
5. lift the evaporator assembly to remove the middle partition.

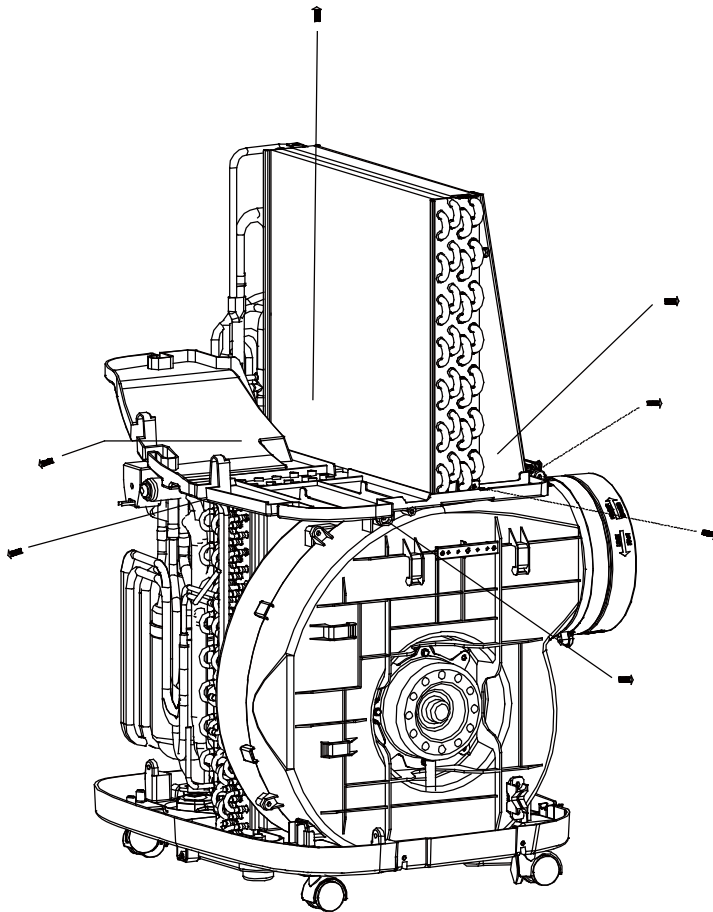

VIII. Dismantling of exhaust duct assemblies

1. remove the 2 fixing screws attached to the chassis at the bottom of the exhaust duct assembly.

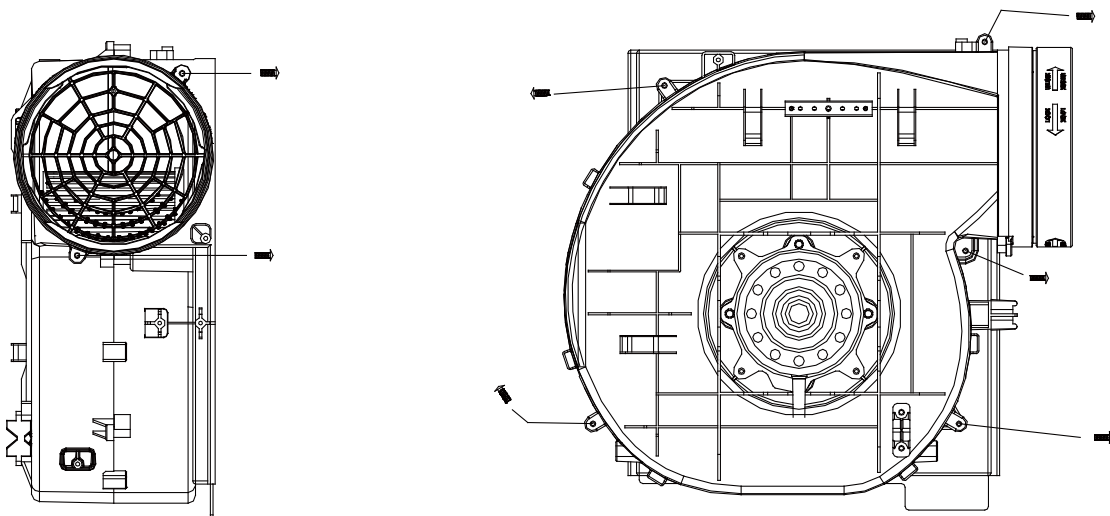

4. loosen the nut fixed on the motor shaft, remove the nut, pull out the exhaust air wheel with both hands; remove the 4 screws fixed on the other side, remove the motor

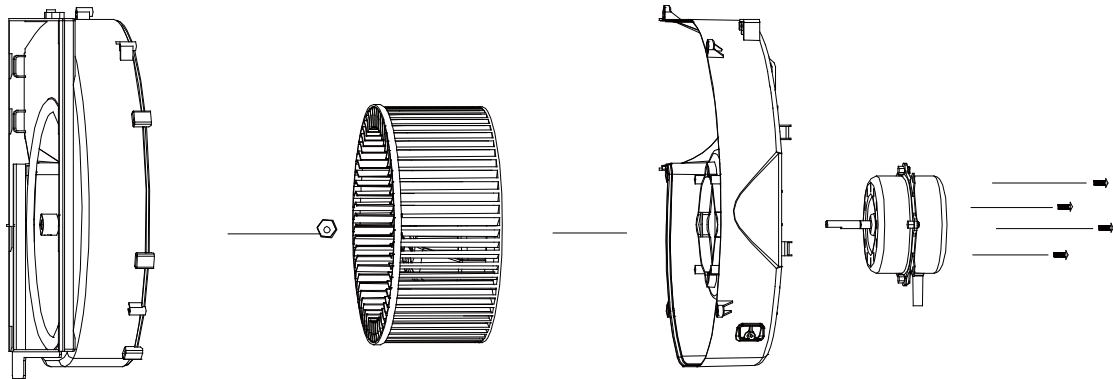

IX. Dismantling of the refrigeration system

1. first remove 2 screws connecting the end plate of the lower condenser to the base
2. the three nuts of the fixed compressor foot are rotated separately, the nut and gasket are taken out, and the refrigeration system composed of compressor, condenser and evaporator is raised upward. (Note that the line must not break) to remove it from the chassis assembly.

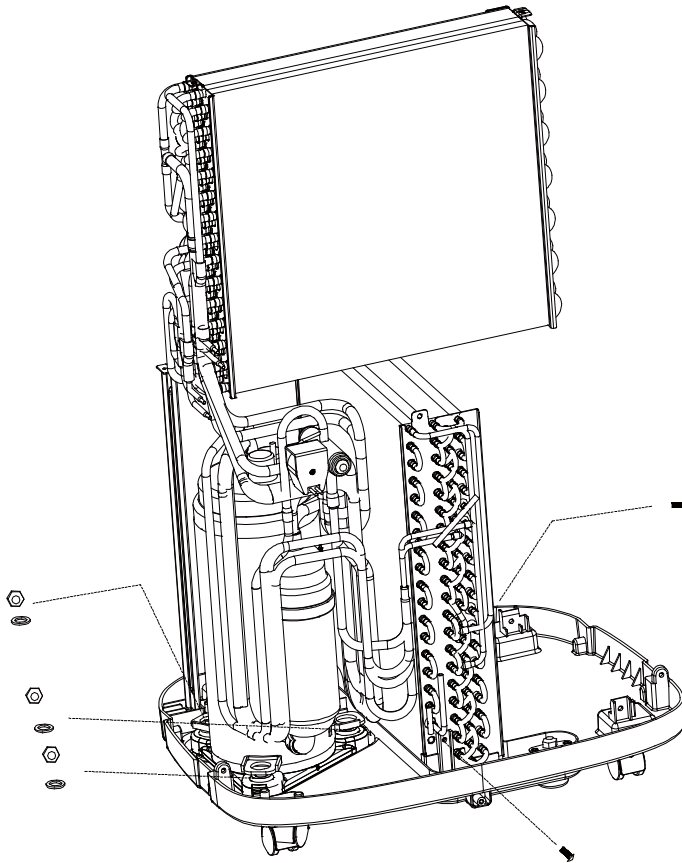

X. Removal of chassis assemblies

1. remove 2 screws for magnetic ring switch assembly
2. remove 1 screw of main bracket.
3. remove 4 screws linking the water puller assembly to the chassis
4. remove 4 universal wheels fixed with chassis, each with only 2 screws fixed with chassis, a total of 8 screws;

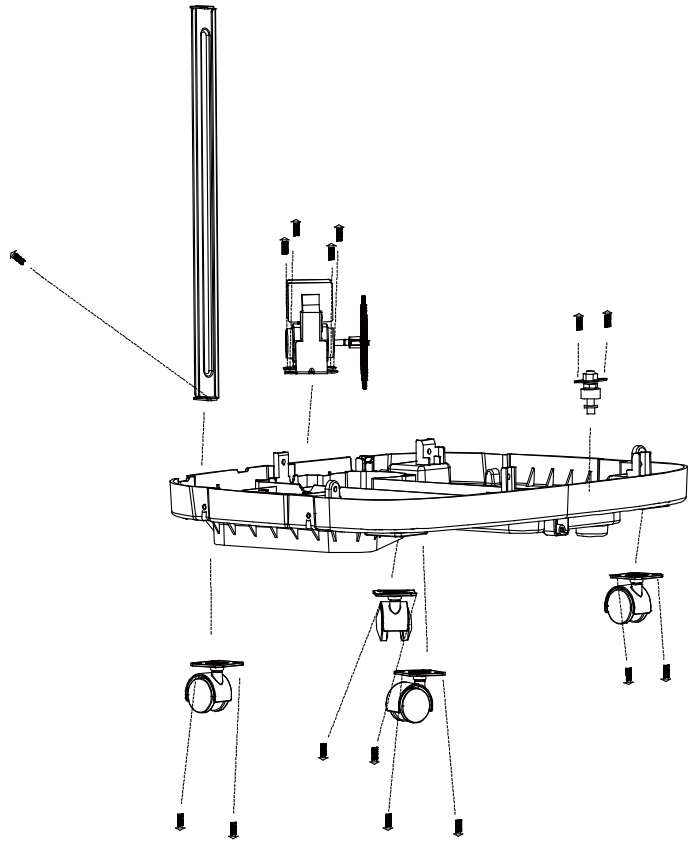

ERIS**REGULATION (EU) No. 517/2014 – F-GAS**

The unit contains R290, a natural greenhouse gas with global warming potential (GWP) = 3 - Kg.
0.22 = 0.00066 Tons CO₂ equiv.

Do not release R290 into the atmosphere.

ERIS PLUS**REGULATION (EU) No. 517/2014 – F-GAS**

The unit contains R290, a natural greenhouse gas with global warming potential (GWP) = 3 - Kg.
0.23 = 0.00069 Tons CO₂ equiv.

Do not release R290 into the atmosphere.



improve your life

www.argoclima.com