



**HYDR**   
*digit*

EN

## ULTRASONIC HUMIDIFIER



## OPERATING INSTRUCTIONS

Read the instructions carefully before operating the appliance or carrying out maintenance operations. Observe all the safety instructions; failure to observe the instructions may lead to accidents and/or damages. Store these instructions.

## GENERAL OPERATING AND SAFETY INSTRUCTIONS

- The appliance is a highly effective humidifier: use this humidifier only as outlined in this manual. Any other use not recommended by the manufacturer may cause fire, electric shock or malfunctions.
- Ensure that the mains voltage complies with that indicated on the data plate (220-240VAC/50Hz).
- This appliance can be used by children aged from 8 years and above and people with reduced physical, sensory or mental capabilities or lack of experience and knowledge if they have been given supervision or instruction concerning use of the appliance in a safe way and understand the hazards involved.
- Children shall not play with the appliance.
- Cleaning and user maintenance shall not be made by children without supervision.
- This product is not a toy. Children should be adequately supervised to ensure that they do not play with the appliance.
- This appliance is not suitable for use by persons (including children) with reduced physical, sensory or mental abilities, or without the necessary experience and knowledge, unless they have been adequately supervised and instructed concerning use of the appliance by a person responsible for their safety.
- **Disconnect the mains power when the appliance is not used or for cleaning operations. Keeping the plug inserted may cause electric shocks or accidents.**
- To disconnect the appliance, push the switch to OFF and remove the plug from the socket. Pull on the plug only. Do not pull on the cord when turning off the appliance.
- Do not insert any objects or needles in the mist discharge nozzle or in the compartment next to the handle. This may cause electric shock, malfunctions or other accidents.
- Do not bend, drag and twist the cord or apply force to remove it. **Do not use the appliance if the cord or plug are damaged: this may cause the risk of fire or electric shock.** If the power supply

cord is damaged, it must be replaced by the service centre, so as to avoid any safety risks.

- Do not use the appliance in the presence of other electric equipment such as computers or precision instruments. The humidity or “white dust” contained in the mist may cause the appliances to malfunction.
- In the event of an anomaly, switch the appliance off and remove the plug immediately. Do not dismantle, repair or modify this product freely. In the event of malfunctions, contact the technical assistance centre directly.
- Do not immerse the cord, plug or any other element of the appliance in water or other liquids.
- Do not touch the plug with wet hands.
- Do not inhale the mist discharged from the nozzle.
- Do not use acidic or basic solvents for cleaning the interior of the appliance: the residues may hamper its efficient operation.
- Do not operate the appliance on unstable surfaces, as the water flowing out of the appliance may wet the floor or cause malfunctions. Do not place the appliance on a high or sloping surface, as it may fall as a result of vibrations or accidental knocks. Placing the appliance on a sloping surface may cause the humidifier’s water level control device to malfunction, thereby causing an interruption in operation or loss of water.
- Do not expose the humidifier to direct sunlight or place it above or adjacent to an air conditioner: this may cause warping, loss of heat or anomalies during operation.
- Do not place the appliance on furniture or supports with poor heat resistance: this may cause warping or fading of the support due to overheating.
- Do not place the appliance in environments characterised by strong magnetic fields: this may cause anomalies during operation.

- Do not place the appliance on blankets or carpets as these may block the entry of air underneath the appliance and cause faults or malfunctions.
- Do not place the appliance on or close to furniture or curtains. The mist may wet the furniture or curtains causing them to fade or deform. Moreover, the “white dust” included in the mist may alter the surfaces of furniture: therefore, the mist jet should not be directed towards furniture.
- Do not operate the appliance in close proximity to bathtubs, showers, washbasins or pools.
- Fill the water tank with clean water on a daily basis. Remove any residual water in the tank after every use. Clean the water tank and nebuliser every one or two weeks and keep them clean. Do not add any aromatic fragrances to the water in the tank.
- Do not connect the appliance to the mains supply if the water tank is empty or if the appliance is upside-down: this will cause the nebuliser to malfunction.
- Do not move the appliance during operation as water leakages or malfunctions may result.
- During winter, the water in the tank may freeze and cause the appliance to malfunction. Remove the water from the tank.
- Carry out maintenance on the appliance by regularly and thoroughly cleaning the tank and nebuliser. Continuous operation of the appliance with dirt residues may lead to faults and malfunctions.
- The internal ultrasonic nebuliser is highly sensitive. Do not touch it with fingers or rub it with metal accessories to avoid reducing mist emission.
- Do not use hot water to avoid damaging the parts that generate mist.

**WARNING:**

**THE ON/OFF SWITCH IS NOT THE ONLY MEANS TO DISCONNECT THE POWER SUPPLY. ALWAYS PULL OUT THE PLUG FROM THE SOCKET IN THE EVENT OF MAINTENANCE OPERATIONS, WHEN MOVING THE APPLIANCE OR WHEN THE LATTER IS NOT USED.**

**DESCRIPTION OF THE APPLIANCE**

**DIGITAL DISPLAY**

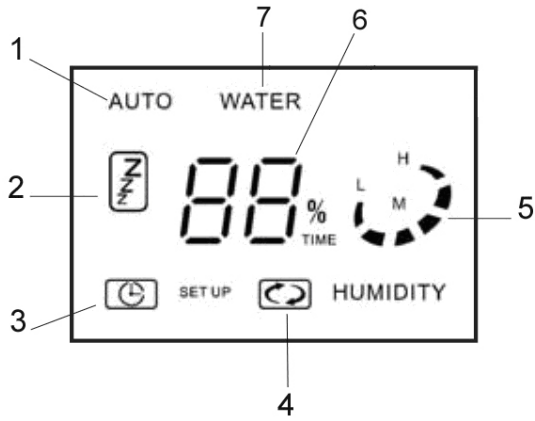

- 1) AUTO mode
- 2) QUIET mode
- 3) Timer 1-8 hours
- 4) Continuous operation
- 5) Mist emission level (low, medium, high)
- 6) Humidity (%) detected by the sensor
- 7) Lack of water warning light

The mist discharge nozzle can rotate through 360°: the direction of the mist may be freely adjusted.

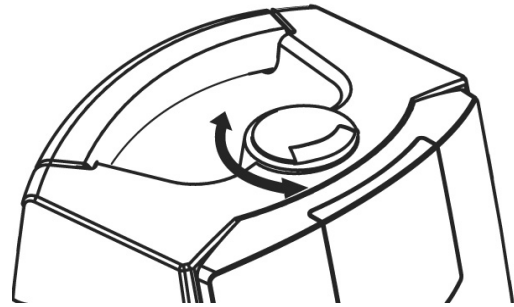

## DESCRIPTION OF THE APPLIANCE

**WARNING:** when moving the appliance, do not grip the tank handle (1) but hold the appliance from the bottom.

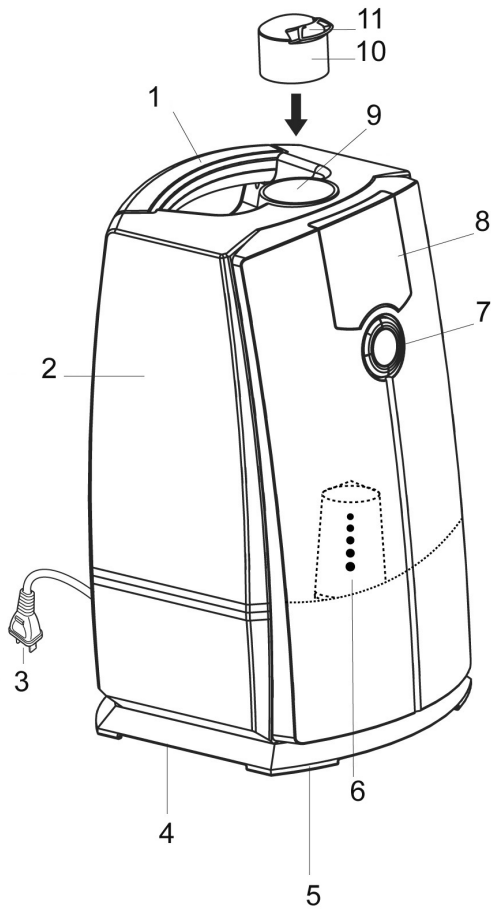

- 1) Tank handle
- 2) Water tank
- 3) Plug
- 4) Air inlet on bottom
- 5) Temperature and humidity sensor
- 6) Ion exchange filter
- 7) Controls
- 8) Display
- 9) Nozzle insertion position
- 10) Nozzle
- 11) Discharge nozzle

## CONTROLS

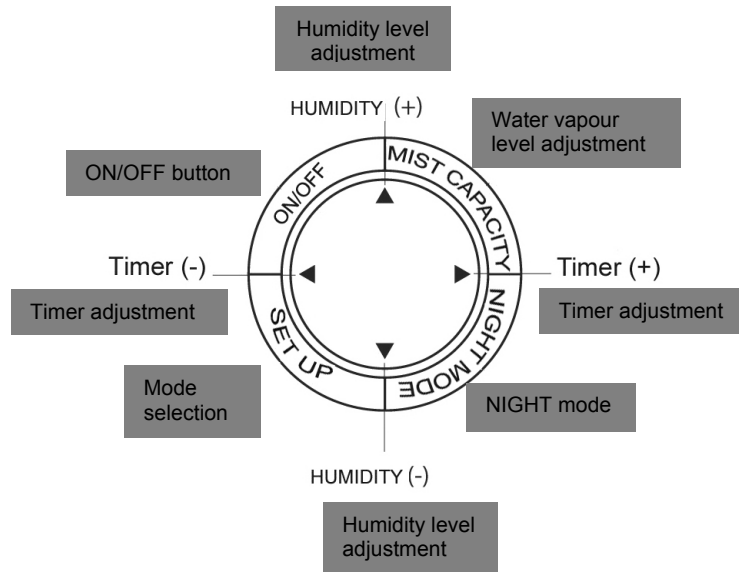

## INTERIOR

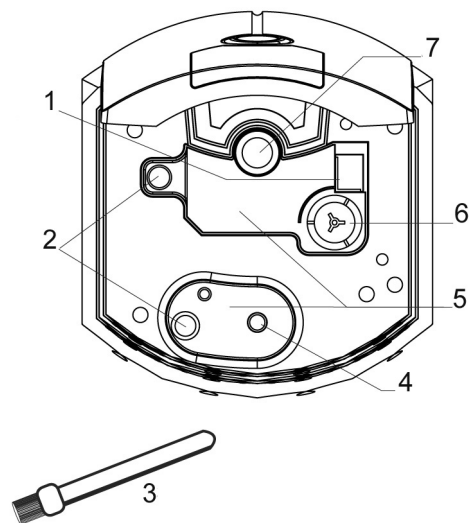

- 1) Air discharge
- 2) Water intake
- 3) Brush
- 4) Water inlet valve insertion
- 5) Water tank
- 6) Buoy
- 7) Nebuliser

## OPERATING INSTRUCTIONS

### FILLING THE WATER TANK

1. **Firstly, remove the mist discharge nozzle from the water tank**, by simply turning the appliance upside-down.

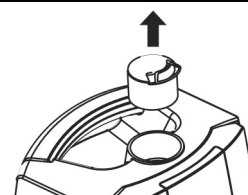

2. **Remove the water tank from the appliance**, by simply pulling the handle upwards.  
Remove the plug on the bottom of the tank by unscrewing it anti-clockwise.

**WARNING:** when moving the appliance, do not grip the tank handle but hold the appliance from the bottom.

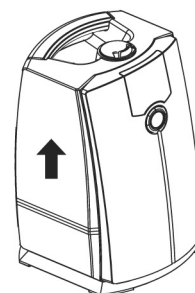

3. **Fill the water tank exclusively with tap water, without adding any aromatic fragrances or essences.**

- Do not fill the tank with liquids other than tap water. Liquids with different composition may damage the humidifier's internal components and cause malfunctions.
- Do not add essences, perfumes, detergents, chemical agents, hot water (above 40°C) etc. to the water in the tank as these may damage the humidifier's water tank or several internal components and cause malfunctions.
- Do not add water directly inside the bottom section of the appliance beneath the tank, or in the discharge nozzle. The water that may penetrate inside the bottom section of the appliance may cause malfunctions.
- Do not knock or throw the water tank as it may break or cause water leakages. Do not use the water tank if it has suffered heavy knocks. Contact the technical assistance service as soon as possible.
- Fill the humidifier with clean water daily and keep it clean.

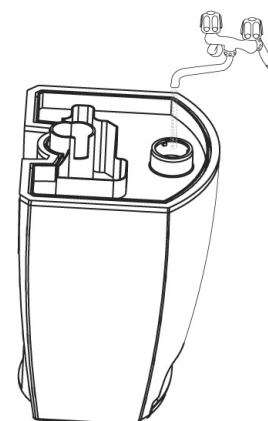

4. **Close the water tank plug correctly.**

Ensure that the rubber ring has been placed on the tank plug then tightly secure the latter by turning it anti-clockwise, to prevent air from entering the tank and causing possible malfunctions.

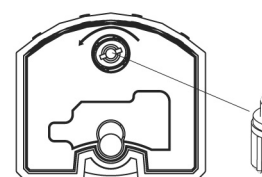

5. **Replace the water tank and mist discharge nozzle.**

Properly replace the water tank and mist discharge nozzle inside the tank before starting the appliance, or the discharged mist will wet the humidifier and surrounding environment.  
Do not move the humidifier after putting the tank back in place, as this may cause water leakages and possible malfunctions.

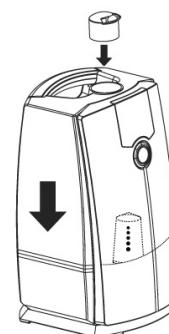

## HOW TO ACTIVATE THE HUMIDIFIER

**1. Insert the power supply plug in the socket:** the humidifier will emit a buzzer sound.

**⚠ WARNING!**

Use alternating current (AC) as specified on the data plate. Higher voltages may cause the risk of malfunctions, fire or electric shock.

**⚠ WARNING!**

Do not use the humidifier if the cord or plug are damaged, or if the plug does not fit tightly into the socket. This may cause sparks, short-circuits or electric shocks.

**⚠ WARNING!**

Do not activate the humidifier if water has overflowed or when the appliance is upside-down, as this may cause malfunctions.

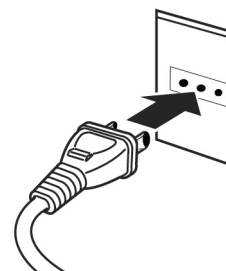

**2. Press the “ON/OFF” button.**

- Press the “ON/OFF” button: the appliance emits a buzzer sound and activates.
- The display visualises “AUTO” and mist starts coming out of the discharge nozzle.
- The display visualises the level of humidity detected in the environment, and the vapourisation mode activates automatically.
- Ten seconds after pressing the ON/OFF button, the indicator light signalling the amount of mist turns on/off continuously (preparatory stage prior to activation).
- In the initial stages of operation, the amount of mist emitted may be unstable: this is due to the difference in temperature and quality of the water. The humidifier requires some time before the nebuliser transforms water into mist and stabilises the flow.
- The mist flow stabilises after 10-25 minutes of operation.

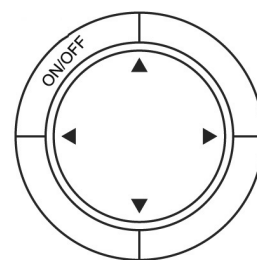



# OPERATING INSTRUCTIONS

## OPERATION IN THE "AUTO" MODE

The AUTO mode automatically activates after pressing the ON/OFF button when turning on the humidifier, without selecting any function.

In this mode, the sensor installed inside the humidifier detects the temperature and humidity of the surrounding atmosphere and compares the values with the most appropriate humidity % for the environment (as calculated in relation to the latter's temperature), and accordingly adjusts the appliance's operation so as to achieve the optimal humidity level for the given temperature conditions.

Ambient temperature	Most appropriate humidity level
<19°C	65%
20~21°C	60%
22~24°C	55%
>25°C	50%

The AUTO mode may also be selected by pressing the SET UP button: each time this button is pressed, the humidifier sequentially switches from the "QUIET" mode to the "CUSTOM SETTINGS" mode to the "AUTO" mode.

## ADJUSTING THE HUMIDITY LEVEL IN THE "AUTO" MODE

The mist emission is automatically adjusted in relation to the difference between the detected humidity and the ideal humidity.

Mist level adjustment in the AUTO mode

When the tank is filled with water, the "WATER" signal initially lights up in red on the display, but after 2-5 seconds the humidifier activates (it takes roughly 2-5 seconds for the water to pass from the tank to the underlying slot where the nebuliser is located).

Difference between the appropriate humidity level and the current humidity level (%).	Mist emission level (operation display)
>16	High level
>4<15	Medium level
<3	Low level
The current humidity is higher than the appropriate humidity.	Mist emission stops

## OPERATION IN THE "QUIET" MODE

To select this mode, press the "SET UP" button once while the appliance operates in the automatic mode.

- The indication "Zzz" on the display signals that the "QUIET" mode has been set.
- The ideal level of humidity in this mode is 50%.

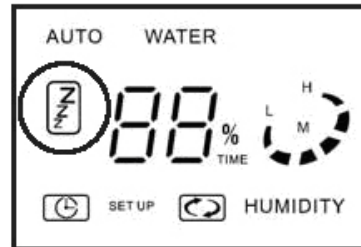

When the water in the tank is used up, the buzzer does not sound in this mode: the signal "WATER" simply lights up and the appliance stops.

Mist level adjustment in the QUIET mode.

Difference between the appropriate humidity level and the current humidity level (%).	Mist emission level (operation display)
>16	High level
>4<15	Medium level
<3	Low level
The current humidity is higher than the appropriate humidity.	Mist emission stops

**The humidity level that appears on the display is that detected by the sensor inside the product. It does not correspond to the actual humidity in the environment.**

## OPERATION IN THE "NIGHT" MODE

The NIGHT mode automatically activates after pressing the NIGHT button, to reduce the display brightness at night.

## OPERATING INSTRUCTIONS

### CUSTOM SETTING MODE

Press the "ON/OFF" button to start the appliance. Press the "Set up" button repeatedly to set the desired operating mode.

Once the desired mode has been set, the mist emission level can be freely adjusted (to high, medium or low), the % of humidity and the timer.

### MIST EMISSION ADJUSTMENT

By pressing the "MIST CAPACITY" button each time, the amount of mist emitted can be adjusted (low=L; medium=M; high=H). The display will indicate the set level.

The discharge nozzle does not emit any mist if the ambient humidity is higher than the pre-set humidity level.

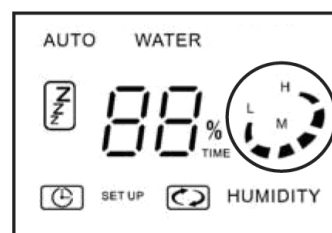

### SELECTING THE MOST APPROPRIATE HUMIDITY LEVEL

The most appropriate humidity level can be selected by pressing the upper and lower buttons of the humidity adjustment switch. The setting range varies from 40% to 80%, in 5% intervals.

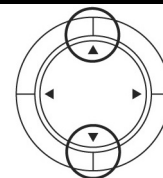

### TIMER ADJUSTMENT

The operating time can be adjusted by pressing the left and right buttons on the timer. The setting range varies from "continuous operation" to 8-hour operation, with 1 hour intervals between the steps.

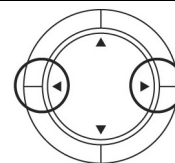

## OPERATING INSTRUCTIONS

### HOW TO TURN OFF THE HUMIDIFIER

1. Press the ON/OFF button, the indicator lights on the display start fading. Press the ON/OFF button again, a buzzer sounds and the humidifier turns off.
2. Remove the plug from the socket.

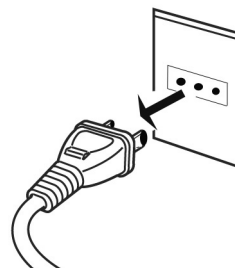
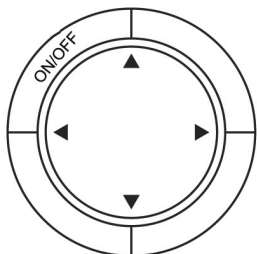

### MIST EMISSION WITH A FULL TANK

#### **WITH THE WATER TANK FULL**

When the humidifier operates in:

- “Low” mode: it may humidify continuously for roughly 60 hours.
- “Medium” mode: it may humidify continuously for roughly 30 hours.
- “High” mode: it may humidify continuously for roughly 20 hours.

#### **⚠ WARNING!!**

It is normal for water to accumulate on the bottom of the appliance, as water in the tank passes through to the appliance’s base in order to initiate the ultrasonic humidification process. Be careful when removing the water tank for filling/emptying or cleaning operations, as the water accumulated on the bottom may drip from the tank.

### WHEN THE WATER IN THE TANK IS USED UP

- When the water in the tank is used up, the humidifier stops functioning; the lack of water is signalled by a buzzer sound while the WATER indicator light starts flashing.
- To restore appliance operation, add water by following the aforementioned procedure.
- Be careful when lifting the water tank as it may leak; dry the tank with a cloth to avoid wetting the floor or furniture.
- When adding water to the tank, be careful not to drop or knock the latter as it may break.

#### **⚠ WARNING!!**

- After using the appliance for a certain period of time, limescale deposits may build up in the water tank and nebuliser. It is advisable to clean the water tank and nebuliser once or twice a week and to operate the appliance when it is clean; limescale deposits may cause the appliance to malfunction.
- In order to ensure constantly efficient operation, the water in the tank should be changed everyday.

## PARTS TO BE REPLACED

### ION EXCHANGE FILTER

- A removable ion exchange filter is housed inside the humidifier: its function is to remove the calcium and magnesium salts normally contained in water, as these may turn into “white dust” if they vaporise and deposit on furniture, objects and floors.
- For this reason, it is important to replace this filter regularly.
- The ion exchange filter may cause the water to assume a tea-like colour in the initial stages of operation. This effect does not impact the appliance’s safety or performance, although the coloured water should be replaced with clean water.

### REPLACING THE FILTER

- The ion exchange filter is able to effectively filter water up to approximately 400 litres. Using the device beyond this limit will lower its ability to remove substances that harden the water (calcium and magnesium). Consequently, this may generate increased levels of “white dust”.
- In standard conditions, the filter must be replaced after approximately 180 days of use in the auto mode.
- Depending on the frequency of use and quality of the water, the filter may require replacement even sooner than the above-mentioned limit. Therefore, it is important to monitor the build-up of limescale deposits.
- The ion exchange filter is installed on the bottom of the water tank. To replace the filter, both the cover and filter must be removed by rotating them anti-clockwise. Install the new filter by rotating it clockwise, as shown in the picture, and put the cover back in place by rotating it clockwise.

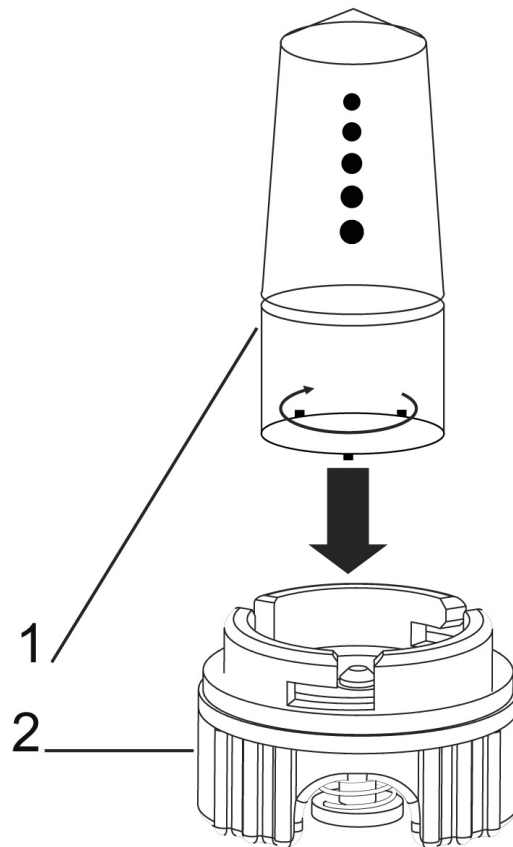

1. Ion exchange filter.
2. Water tank plug.

## CLEANING AND MAINTENANCE

### PRECAUTIONS

#### ⚠ Warning

- Always remove the plug from the socket before cleaning the appliance, or electric shocks and malfunctions may occur.

### MAINTENANCE OF THE HUMIDIFIER'S EXTERIOR SURFACE

Use a damp and soft cloth to clean the humidifier's exterior surface.

#### ⚠ Warning

- Do not wet the appliance or immerse it in water to avoid electric shocks.
- Do not use solvents, petrol, xylene, talcum powder and brushes: these products may damage the surface or alter the casing colour.

### CLEANING THE WATER TANK

- Remove dirt from the water tank with the aid of a soft, damp cloth.
- Use the brush supplied with the humidifier to remove deposits from the smallest components then clean with a damp cloth.
- Clean the appliance once or twice a week.

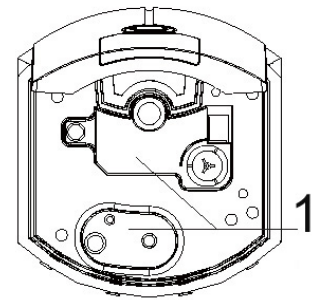

1. Water tank

### CLEANING THE BUOY

- Ensure that no dust is deposited around the buoy and clean the latter using the brush supplied with the humidifier: remove any deposits from the smallest components then wipe with a damp cloth.
- Clean the humidifier once or twice a week.

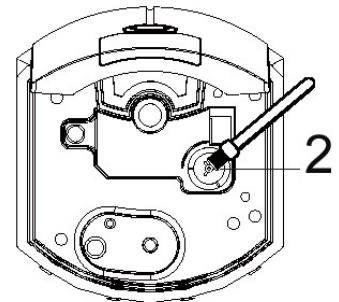

2. Buoy

### CLEANING THE NEBULISER

- Clean the deposits on the nebuliser using the brush supplied with the humidifier then wipe with a damp cloth.
- Clean the humidifier once or twice a week.

#### ⚠ Warning

- Do not use metal brushes, metal blades, abrasive brushes or talcum powder to clean the nebuliser surface. These products may deform the nebuliser or cause abrasions, thereby leading to reduced mist emission and other malfunctions.

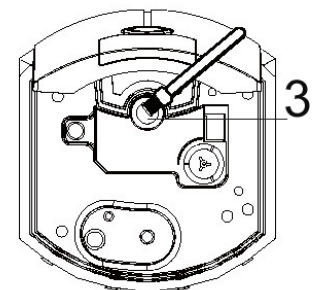

3. Nebuliser

## CLEANING AND MAINTENANCE

### MAINTENANCE OF THE WATER TANK AND DISCHARGE NOZZLE

1. Remove the discharge nozzle and unscrew the plug on the bottom of the tank by turning it anti-clockwise to eliminate the residual water. The discharge nozzle will fall if it is not removed before eliminating the water.
2. Clean the water tank and relative plug using clean water. Clean the water tank plug carefully, without applying force, so as to avoid water leakages from the plug itself.
3. After having removed the deposits from the surface of the discharge nozzle, dry the latter with the aid of a soft cloth.

#### Warning

- Avoid heavy knocks to the water tank as this may cause water leakages.
- Interrupt humidifier operation immediately in the event of leakages and contact the technical assistance service directly.

### STORAGE AFTER USE

1. Ensure that no residual water is left in the tank and inside the appliance.
2. Leave the tank and appliance to dry naturally and completely before storing the product.
3. Place the water tank and appliance in a plastic bag then in the original box and store in a cool, dry place.

#### Warning

- The humidifier may seize or fail to function correctly if stored without being fully dried. Ensure that the humidifier is completely dry before storing it away.

#### INFORMATION ON PROPER DISPOSAL OF THE APPLIANCE IN COMPLIANCE WITH EUROPEAN DIRECTIVE 2012/19/EU



When this appliance reaches the end of its useful life, it must not be disposed of together with household waste but must be delivered to appropriate separate waste disposal plants or to dealers that provide similar service. Separate waste disposal of electrical and electronic appliances prevents possible negative effects on the environment and human health resulting from inadequate disposal, and also allows for recovering and recycling the materials comprising the appliances to ensure significant saving in terms of energy and resources. The separate disposal obligation is underlined by the crossed-out dustbin symbol appearing on the product. Illegal disposal of the product by the user shall determine the application of the administrative sanctions defined by the regulations in force.

## TROUBLESHOOTING

- In the event of malfunctions, check the following points before contacting the technical assistance centre.
- Should you not be able to solve the problem, please contact the technical assistance centre nearest to you.

Problem	Possible cause	Suggested solution
The appliance does not emit mist.	The plug is not properly inserted into the socket.	Insert the plug properly into the socket.
	The "WATER" indicator light on the display turns on/off (the water tank is empty).	Add water in the tank.
The appliance emits very little steam.	The appliance is operating in the "LOW" mode (the display visualises "LOW").	It is not a fault. To increase the amount of mist, select the "HIGH" mode by pressing the "MIST CAPACITY" button.
	There are some deposits on the nebuliser's surface.	Clean the nebuliser.
The difference between the ambient humidity and the humidity detected by the internal sensor is too high.	The air intake slots are dusty.	Clean the air inlet slots. Humidity levels may vary in different points even of the same room.
	The humidifier is positioned in a spot highly exposed to the outside environment, for example near a window.	Place the humidifier in a spot that is not exposed to the outside environment.
A strange smell is emitted with the mist.	The water in the tank is not fresh.	Clean the humidifier according to the instructions and replace the water in the tank with fresh water.
	Deposits or dirt have built up inside the water tank or nebuliser.	
A "pu....." sound is heard.	It is the sound of water flowing from the tank to the slot.	It is not a fault, continue using the appliance normally.
A "po....." sound is heard.	It is the noise of the fan.	



[www.argoclima.com](http://www.argoclima.com)