



EN

DEHUMIDIFIER

PLATINUM 21

PLATINUM 41



OPERATING INSTRUCTIONS

Read the instructions carefully before operating or servicing the dehumidifier.
Observe all the safety instructions; failure to observe the instructions may lead to accidents and/or damage.
Keep these instructions in a safe place for future reference.

GENERAL OPERATING AND SAFETY INSTRUCTIONS

- **This appliance is a highly efficient dehumidifier, designed for domestic use only!**
- Use this dehumidifier only as outlined in this manual. Any other use not recommended by the manufacturer may cause fire, electric shock or malfunctions.
- The unit contains refrigerant; keep it vertical at all times.
- Once you have opened the unit, keep it vertical to allow the refrigerant to stabilise and wait two hours before operating it.
- Ensure that the required voltage and frequency (220-240V/50Hz) match the available power source(220 - 240V/50Hz).
- This appliance can be used by children aged from 8 years and above and people with reduced physical, sensory or mental capabilities or lack of experience and knowledge if they have been given supervision or instruction concerning use of the appliance in a safe way and understand the hazards involved.
- Children shall not play with the appliance.
- Cleaning and user maintenance shall not be made by children without supervision.
- Make sure the plug is inserted fully. Do not use multiple adapters. Do not touch the plug with wet hands. Make sure the plug is clean.
- Children aged between 3 and 8 years must only be able to turn the appliance on/off, provided that the appliance has been placed in its normal operating position, that instructions have been given on how to use the equipment safely, and that its risks have been understood.
- Children aged between 3 and 8 years must not be able to plug in, adjust, clean or perform any maintenance on the appliance.
- **Disconnect the mains power when the appliance is not in use or during cleaning. Keeping the appliance plugged in may cause electric shocks or accidents.**
- To disconnect the appliance, set the switch to OFF and remove the plug from the socket. Pull on the plug only. Do not pull the cord.
- Do not bend, drag or twist the cord, or apply force to remove it. **Do not operate the unit if its cable or plug are damaged; doing so**

can cause fires or electric shocks. If the power cord is damaged, it must be replaced by a service centre.

- **Do not place heavy objects on top of the appliance.**
- To prevent water spills, empty the water tank before moving the appliance.
- Do not tilt the dehumidifier onto one side or turn it upside down, as the water which runs out could damage the appliance.
- **Do not operate the unit on unstable or sloping surfaces: water leaks can cause it to malfunction or cause excessive vibration and running noise.**
- The dehumidifier must be positioned **at least 50 cm** away from the wall or other obstacles, so that the heat can dissipate correctly.
- **Close all open windows to maximise dehumidification efficiency.**
- **Do not insert objects or sharp instruments into the air outlet grille.**
- **Do not cover the air intake and outlet grilles in any way.**

WARNING!

In the event of an anomaly, switch the appliance off and unplug it immediately. Do not dismantle, repair or modify this product freely. In the event of a malfunction, contact the after-sales service centre directly.

- Do not immerse the power cord, plug or any other part of the appliance in water or other liquids.
- Do not expose the dehumidifier to direct sunlight.
- Keep the appliance well away from sources of heat which could cause plastic parts to become warped.
- Do not spray insecticides, oils or paints near the appliance; doing so may damage its plastic parts or start a fire.
- **Keep flammable gases and oils away from the appliance!**
- **Do not move the appliance while it is operating; doing so can cause leaks and malfunction.**

DESCRIPTION OF PARTS

FRONT VIEW

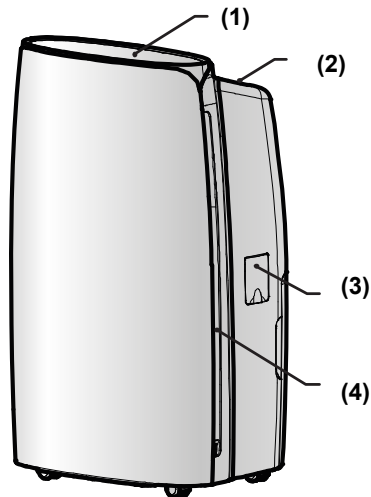

- 1) CONTROL PANEL
- 2) DEHUMIDIFIED AIR OUTLET
- 3) CONTINUOUS CONDENSATION DRAINAGE HOLE COVER
- 4) AIR INTAKE

REAR VIEW

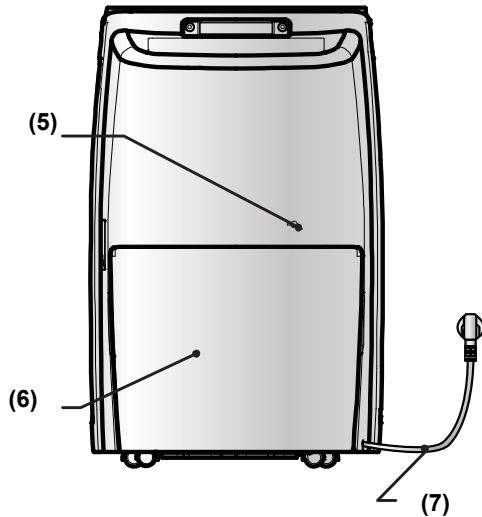

- 5) POWER CORD ATTACHMENT HOLE
- 6) CONDENSATION COLLECTION TANK
- 7) POWER CORD

CHECKS BEFORE START UP

Check that the float and the condensation collection tank are correctly positioned

1. Remove the tank using both hands and following the direction of the arrow.



2. Check the position of the float inside the tank; it may have shifted during the move. If it is not positioned correctly, reposition it before using it.

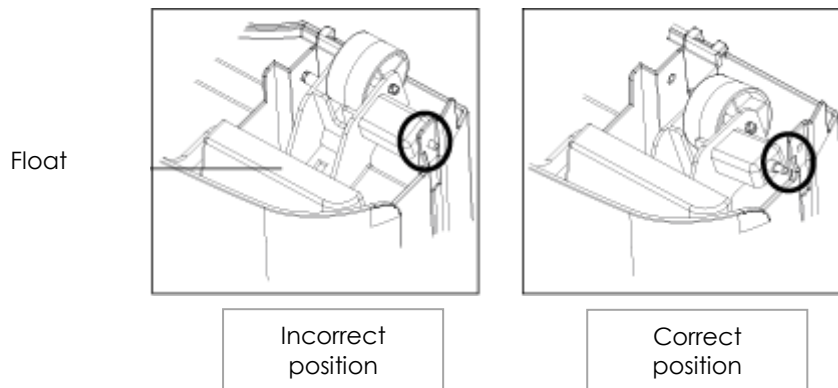

3. Then, reposition the tank.

OPERATING INSTRUCTIONS

APPLIANCE START-UP

Place the product on a flat and stable heat-resistant surface, at least 1 metre away from flammable or heat-sensitive materials and 50 cm away from walls or other obstructions.

Make sure the water tank is in the correct position.

Connect the power cord to a suitable electric socket (220-240V/50Hz).

Power the unit on with the ON/OFF button on the control panel.

The dehumidifier is designed to operate at room temperature **from + 5 °C to + 35 °C**.

If it is operated at low temperatures, ice may form on the evaporator, degrading its operation.

When this happens, the dehumidifier goes into defrost mode. The compressor stops, but the fan continues running.

We recommend not using the dehumidifier in room temperatures lower than 5 °C.

OPERATING PRECAUTIONS

The appliance will only start operating if the humidity level in the room is above the set value.

The dehumidifier will continue to operate until the set humidity level has been reached, **with the exception of interruptions caused by a full tank**. In this case, empty and reinstall the tank: the dehumidifier will now start running again.

WARNING:

After each interruption of its operation, at least 3 minutes must pass before the dehumidifier starts up again: this delay prevents the compressor being damaged.

If, on the other hand, the set humidity percentage is higher than the level currently found in the room, the dehumidifier will not start.

If, after following the start-up instructions, **the dehumidifier does not start** or stops for no reason, make sure the plug and power cord are in good working order. After doing so, wait for 10 minutes and then restart the appliance.

If the dehumidifier still does not start after 10 minutes, or if either the power cord or plug are damaged, switch off the appliance and contact an after-sales service centre.

WARNING:

When the dehumidifier is running, the compressor produces heat and the appliance emits warm air into the room. The room temperature will therefore tend to increase. This is completely normal.

TURNING THE DEHUMIDIFIER OFF

To turn the dehumidifier off, press the ON/OFF button. This shuts off power to the unit.

Unplug the appliance if you do not intend to use it for some time.

REMOVING THE CONDENSATION - FILLING THE INNER TANK

The water extracted from the air can be collected in the rear tank.

When the tank is full, the unit turns off. The FULL TANK led turns on and the unit beeps for about 10 seconds.

To switch off the appliance, press the ON/OFF button and wait a few seconds.

1. Carefully remove the tank using both hands and following the direction of the arrow.
2. Empty the tank.
3. Reposition the tank following the direction of the arrow.

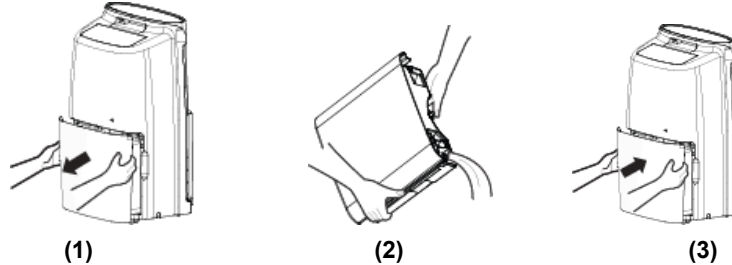

N.B.

Do not use the drain hose when you are collecting condensation in the tank, otherwise water can leak out of the hose.

CONTINUOUS CONDENSATION DRAINAGE

You can fit a PVC hose with an internal diameter of 14 mm and length of 1.3-1.5m(not included) to drain the tank continuously.

Turn off the appliance and remove the plug before connecting the hose.

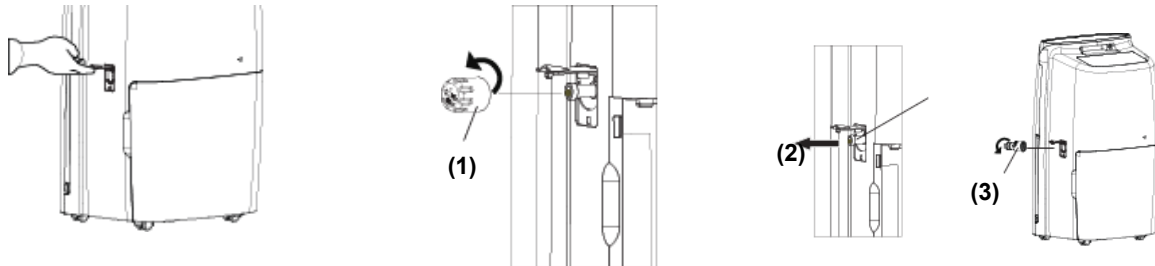

Open the hatch covering the drain hole on the side of the appliance.

To remove the hole cover, turn it in the direction of the arrow (1).

Remove the protective cover (2) and screw the drainage hose adapter (3) (included) onto the drainage hole. Connect a PVC hose (not included) to the continuous drainage hole. Connect the hose to a continuous drainage channel.

The height of the drainage hose must not exceed that of the hole: do not block the drainage hose exit.

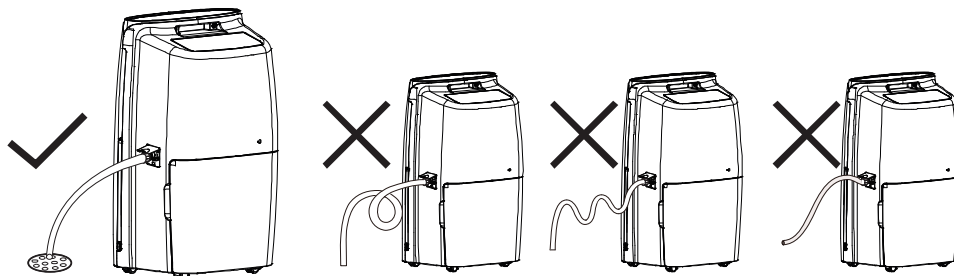

Occasionally check that the adapter and drainage hose are tightly connected and not damaged or blocked.

CONTROL PANEL

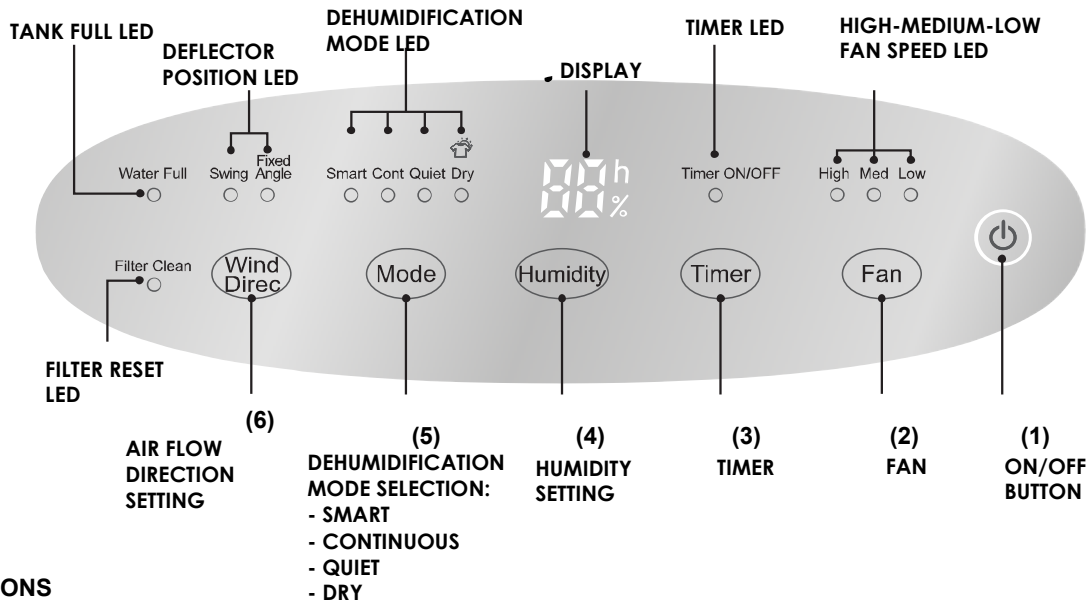

BUTTONS

- (1) **ON/OFF BUTTON:** press to turn the dehumidifier on and off.
- (2) **FAN BUTTON:** press to adjust the fan speed: High, Med, Low.
- (3) **ON/OFF TIMER BUTTON:** the unit can be programmed to switch on (when it is off) and switch off (when it is running) at increments of 1 hour, from 1 to 24 hours. After setting it, the display will show the time per 5".
- (4) **HUMIDITY BUTTON:** In SMART and QUIET mode, the humidity can be adjusted from 30% to 80% at increments of 10%. After setting it, the display will show the set humidity. **The appliance will only start operating if the humidity level in the room is above the set value.**
- (5) **MODE BUTTON:** you can select one of the following dehumidification modes: the corresponding LED will turn on.
- ✓ **Smart:** the unit will intelligently select the optimum humidity level based on the current temperature.
 - ✓ **Cont (Continuous):** the unit will run continuously until the room humidity has reached 50%.
 - ✓ **Quiet:** the unit will intelligently select the optimum humidity level based on the temperature; the fan is kept to a minimum to ensure it is as quiet as possible. In this mode, the fan cannot be adjusted.
 - ✓ **Dry: special laundry drying feature:** the airflow is directed straight up to make it easier to dry the clothes.
- (6) **WIND DIRECT BUTTON:** you can select to make the deflector swing continuously to optimize the airflow around the room, or decide where to fasten the flap (fixed angle).

LED

FILTER CLEAN LED: THE FILTER CLEAN LED will turn on to indicate that the filter must be cleaned. Take the filter out and clean it. Then press the FAN and HUMIDITY button at the same time to turn off the Filter Clean LED.

WATER FULL LED: when the tank is full, the WATER FULL LED will come on and the appliance will stop running. A beep will sound lasting approximately 10 seconds. Remove the tank and empty it (as described in "HOW TO REMOVE CONDENSATION"), then reposition it correctly; the dehumidifier will start running again.

TANK FULL ALARM: when the internal tank is full, or the tank is not correctly positioned, the unit will sound a beep lasting approximately 10": then the LED will turn on. Empty the tank or reposition it correctly.

DEFLECTOR POSITION LED: this indicates your selection of a continuous swing or a fixed angle flap position.

DEHUMIDIFICATION MODE LED: this indicates your selected mode.

DISPLAY: this shows the set humidity.

TIMER LED: this indicates the time it is set to on or off.

FAN SPEED LED: this shows the fan speed: HIGH, MID or LOW.

AUTO-STOP: automatic shut-down of the unit if the tank is full or incorrectly positioned, or when the room humidity is 5% below the set humidity.

AUTO RESTART: the dehumidifier starts up again after a power failure.

MEMORY FUNCTION: the dehumidifier maintains its settings during a power failure.

CHILD LOCK: to disable the buttons, press the Mode and Timer **BUTTONS** for 1 second: the LC symbol will appear on the display. To reactivate the control panel, press the Mode and Timer buttons again for 1 second.

DEFROST: The dehumidifier can function properly with a room temperature **between + 5 °C and + 35 °C**. When the dehumidifier works with a low room temperature, the surface of the evaporator may accumulate ice, which could make the dehumidifier less effective.

When this happens, the dehumidifier goes into defrost mode. The compressor stops, but the fan continues running.

We recommend not using the dehumidifier in room temperatures lower than 5 °C.

CLEANING AND MAINTENANCE

MAINTENANCE OF THE HUMIDIFIER'S EXTERIOR SURFACE

⚠ Warning

Always pull the dehumidifier's plug out of the power socket before cleaning it, to prevent electric shock and malfunction.

⚠ Warning

Do not wet the appliance or immerse it in water, otherwise electric shocks may occur.

Use a damp and soft cloth to clean the exterior surface of the dehumidifier.

Do not use solvents, petrol, xylene, talcum powder or brushes to clean the unit: these may damage the surface or colour of the casing.

CLEANING THE WATER TANK

We recommend removing the tank once every few weeks to prevent mould and bacteria from forming. Fill the tank with clean water a small amount of detergent; swill the water around in it, then it out and rinse it thoroughly.

PLATINUM 21

1. Remove the tank and pour out any remaining water.
2. Press the 4 tabs around on top (1). Lift the cover (2)

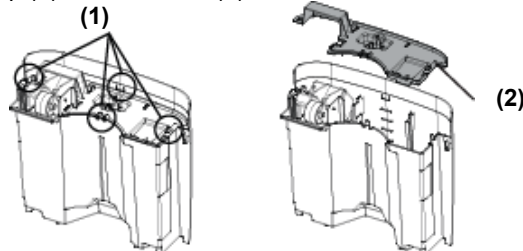

3. After cleaning, replace the cover and check that the float is correctly positioned.
4. The side with the foam must fit together perfectly with the cover. Do not remove the foam from the float.

PLATINUM 41

1. Remove the tank and pour out any remaining water.
2. Turn the handle (3) to lift it and remove it from the cover holes (5).
3. Open the 4 hooks on the cover (4) and lift the cover (6).

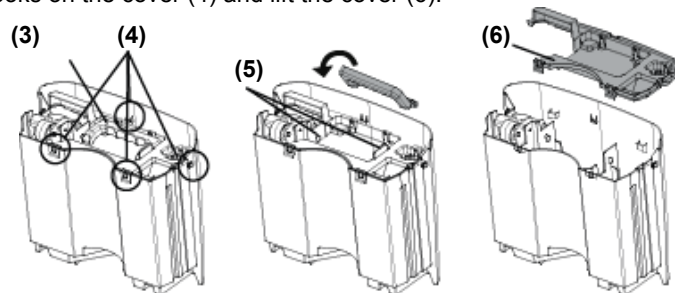

4. After cleaning, replace the cover and check that the float is correctly positioned.
5. The side with the foam must fit together perfectly with the cover. Do not remove the foam from the float.

CLEANING THE AIR FILTER

The filter is designed to remove dust or dirt from the air.

If the filter is clogged by dust, electricity consumption will be higher than normal.

To optimise humidity removal efficiency, clean the filter when the FILTER CLEAN LED turns on.

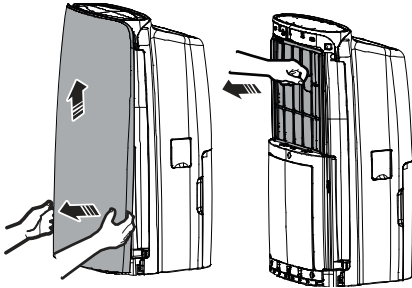

Cleaning instructions:

1. Press the side levers and slightly separate the front panel from the bottom, then the top.

2. Remove the filter by pulling the top towards you.

Clean the filter with a vacuum cleaner or wash it with clean water at no more than 40 °C.

DO NOT USE ALCOHOL, BENZENE OR OTHER AGGRESSIVE PRODUCTS TO CLEAN THE FILTER.

Leave the filter to dry naturally, then reposition it in the relevant slot.

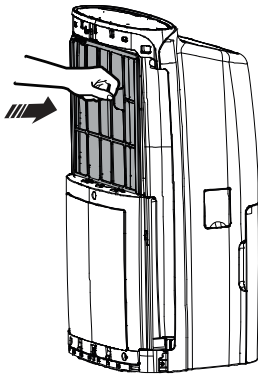

3. Reinsert the filter by fitting the lower hooks into the unit (in the correct "UP" position) and pushing down the filter until you hear a sound.

Do not use the dehumidifier without the filter as dust may affect the efficiency of the evaporator, resulting in higher energy consumption.

TROUBLESHOOTING

PROBLEM	POTENTIAL CAUSE	SOLUTION
The dehumidifier is not working. It is not possible to adjust the settings.	The temperature is above 35 ° C or below 5 °C. The internal tank is full. The tank is not positioned correctly. The set humidity level is higher than that in the room.	Empty the tank Position the tank correctly
The noise suddenly increases while running	The compressor has just started. There is a power connection problem. The unit is placed on an uneven surface.	
Condensation is not collected in the tank	The room is too big for the unit's capacity. The doors are open. There are other devices producing moisture in the room.	
Reduced dehumidification effect	The room temperature is too low. The set humidity level is inadequate. The filter is full of dust. The doors and windows are open. If the unit is running with a temperature between 5 and 15 °C, the unit will pause for automatic defrosting. The compressor will pause for short periods. After the defrost, the unit will resume normal operation.	Reduce the humidity level. Clean the filter. Close any doors and windows.
At first, the air might have a musty smell	Due to the temperature difference of the heat exchanger, the air might have a strange smell at first.	
There is water in the tank even when using the hose for continuous condensation drainage	Check the drainage connections. The drainage hose is not connected properly.	Connect the hose correctly. Remove the drainage hose and replace it.
The ON/OFF LED does not turn on when the power is connected	There is no power or the plug is not inserted correctly.	Check the electrical power supply. Make sure that the electric circuit and plug are not damaged. Make sure that the cable is not damaged.

REGULATION (EU) No. 517/2014 - F-GAS

PLATINUM 21

The unit contains R134A, a fluorinated greenhouse gas with global warming potential (GWP) = 1430 - Kg. 0.185 = 0.265 Tons CO₂ equiv.

Do not release R-134a into the atmosphere.

PLATINUM 41

The unit contains R410A, a fluorinated greenhouse gas with global warming potential (GWP) = 2087.5 - Kg. 0.310 = 0.647 Tons CO₂ equiv.

Do not release R410A into the atmosphere

INFORMATION FOR THE CORRECT DISPOSAL OF THE PRODUCT IN ACCORDANCE WITH EUROPEAN DIRECTIVE 2012/19/EU



This appliance may not be scrapped with domestic waste at the end of its life cycle. We call your attention to the crucial role played by the consumer in the re-use, recycling and other forms of recovery of such waste.

The appliance must be scrapped by a sorted waste disposal centre or by returning it to the retailer (no charge is levied for this service), when you purchase a new equivalent appliance.

Sorted disposal of electric and electronic equipment prevents the negative effects on the environment and human health resulting from improper scrapping, and also allows the materials from which it is made to be recovered and recycled, with significant savings in terms of energy and resources.

The sorted disposal requirement is indicated by the crossed wastebin label affixed to the appliance.



improve your life

www.argoclima.com