



EN

## EVAPORATIVE AIR COOLER

# POLIFEMO BEAR



## OPERATING INSTRUCTIONS

Read the instructions carefully before operating the appliance or carrying out maintenance operations. Observe all the safety instructions; failure to observe the instructions may lead to accidents and/or damage. Keep these instructions in a safe place for future reference.

## GENERAL SAFETY INFORMATION

- Only use this appliance as described in this manual. Any other use not recommended by the manufacturer may cause fire, electric shock or injury to people.
- Do not use this appliance outdoors, this product is for indoor use only.
- Make sure that the type of mains power complies with the electrical requirements of the appliance (220-240V~/50 Hz).
- It is necessary to use a qualified socket that has been checked, and that meets the requirements.
- This appliance can be used by children aged from 8 years and above and people with reduced physical, sensory or mental capabilities or lack of experience and knowledge if they have been given supervision or instruction concerning use of the appliance in a safe way and understand the hazards involved.
- Children shall not play with the appliance.
- Cleaning and user maintenance shall not be made by children without supervision.
- This product is not a toy. Children should be adequately supervised to ensure that they do not play with the appliance.
- **Do not use the appliance if the cord or plug is damaged.** If the power supply cable is damaged, it must be replaced by the manufacturer or its technical assistance service, or in any case by a person with similar qualifications, in order to prevent any risk.
- The appliance must be installed in accordance with national wiring regulations.
- Disconnect the mains power when the appliance is not used or for cleaning operations.
- Unplug the appliance during filling and cleaning.
- Do not touch the power plug with wet hands, there is a danger of electric shock.
- When unplugging the power cord, do not pull on the cord.
- Do not bend the power cord or place heavy objects on it. Do not use extension cables.
- Do not place the appliance under a power socket, do not use the appliance in a bathroom or near a swimming pool.
- During use, make sure that the power cord plug is free from foreign bodies and fully insert the plug into the power outlet.

- **In case of anomalies, switch off the appliance immediately, do not try to repair it, and take it to the local technical assistance center.**
- Do not disassemble or replace the parts by yourself, this may affect the safety of the product.
- If, during operation, an abnormal smell or sound comes out of the product, immediately turn off the appliance and disconnect the power supply.
- Do not block the air inlet and outlet grilles and do not insert objects, they could cause leaks, short circuits and damage to the product.
- Do not expose the cooler to direct sunlight, because the color of the materials could be altered and the appliance overheating.
- **Do not use insecticides, oils, detergents, flammable or explosive sprays or spray paints around the appliance; do not use aggressive chemical detergents to clean the casing: this could damage the finish and color.**
- Do not spill water on the product: risk of short circuit and damage to the appliance.
- Do not ingest battery, Chemical Burn Hazard.
- This product contains batteries. If the battery is swallowed, it can cause severe internal burns in just 2 hours and can lead to death.
- Keep new and used batteries away from children.
- If the battery compartment does not close securely, stop using the product and keep it away from children.
- If you think batteries might have been swallowed or placed inside any part of the body, seek immediate medical attention.
- The batteries contain materials, which are hazardous to the environment; they must be removed from the appliance before it is scrapped and that they are disposed of safely.
- Be aware that high humidity levels may encourage the growth of biological organisms in the environment.
- Do not permit the area around the humidifier to become damp or wet. If dampness occurs, turn the output of the humidifier down. If the humidifier output volume cannot be turned down, use the humidifier intermittently. Do not allow absorbent materials, such as carpeting, curtains, drapes, or tablecloths, to become damp.
- Never leave water in the water tank when the appliance is not in use.

- Empty and clean the humidifier before storage. Clean the appliance before next use.
- Non lasciare a lungo la mandata dell'aria diretta verso un bambino: non è salutare.
- Do not leave the air flow directed towards a child for a long time: it is not healthy.
- After adding water to the tank, do not tilt or bump the product when placing or moving it, to avoid splashing. If the tank has been emptied but there is water in the machine, unplug it immediately and wait 24 hours before turning it on.
- The water level in the water tank must not exceed the maximum level line. When the cooling and humidification functions are activated, the water level in the water tank must not be below the minimum level line.
- When the tank is full of water, do not grab the handle to lift the whole machine, otherwise the water in the water tank may flow out, push gently to move the product using the handle. After making sure there is no water in the tank, lift the whole machine.
- During humidification, it is strictly forbidden to disassemble and assemble the filter and the evaporative panel, as water drops could escape from the air outlet.

## DESCRIPTION OF PARTS

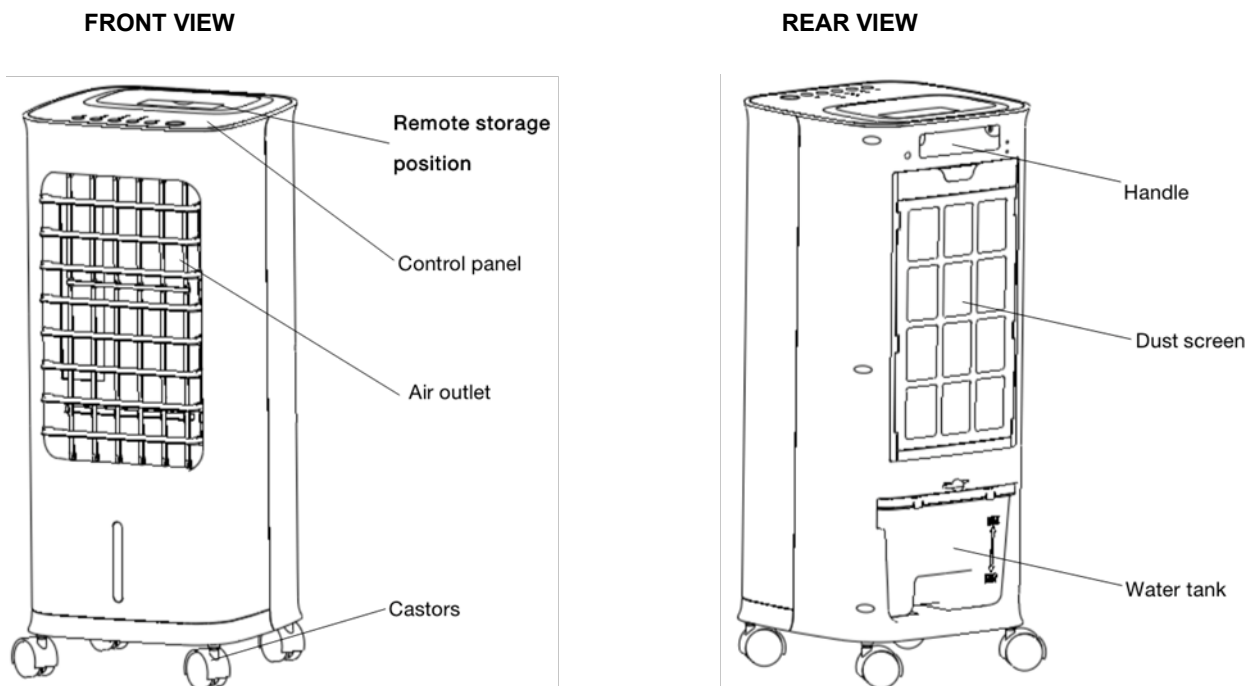

## HOW TO USE THE APPLIANCE

The appliance does not need to be installed.

Position the unit on a flat, stable surface and connect the power cord to a suitable power socket (220-240 V~ 50Hz): the appliance can be switched on using the ON/OFF button and you will hear a sound.

When you move it, use the handle on the back. Do not use this cooler in an area with high humidity, rich in dust or with a temperature above 40 °C.

This product can be used either **as a fan**, with **3 modes (Normal, Natural and Sleep)** and **3 fan speed options (low, medium and high)**, or **as a cooler/humidifier**: in this case the rear tank should be filled with **demineralized water**, up to but not exceeding the maximum level as indicated. When the water in the tank falls below the minimum level, marked on the tank, LED COOL on control panel will flash to indicate the leak of water.

The fan takes in air from the room and passes it through the dust filter and the evaporative panel, which is constantly humidified thanks to a system which draws water from the tank and sprays it onto the panel. The incoming hot air makes part of the water contained in the panel evaporate and is therefore cooler when released back into the room, which makes it feel as though the temperature has dropped.

## REMOTE CONTROL

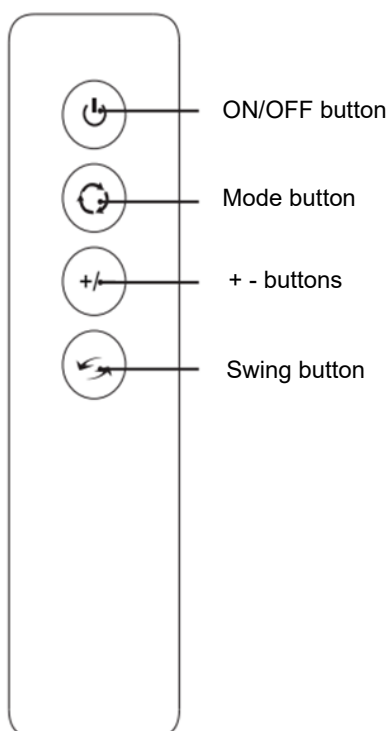

The buttons on the remote control have the same functions as those on the control panel.

To activate the functions, follow the procedures illustrated on the next page.

Insert 2 batteries into the remote control, respecting the polarities indicated. Use only AAA 1.5V batteries.

Remove the batteries if the remote control is not used for a month or longer.

Do not try to recharge the batteries.

Replace all the batteries at the same time.

Do not throw the batteries into fire: they could explode.

### Replacing the batteries of remote control

1. Remove the cover from the compartment containing the batteries.
2. Insert the batteries (AAA, LR03, 1,5V - not supplied) into the remote control, respecting the polarities indicated.
3. Put the lid back on.
4. Point the remote control at the receiver on the air cooler.
5. The remote control should be placed within 6 meters of the receiver.
6. There must be no obstacles between the remote control and the receiver.
7. Do not drop or throw the remote control.
8. Do not put the remote control under strong sunlight or heating devices and other heat sources.
9. Remove the battery from the remote control when it is not used for a long time.
10. Exhausted batteries must be disposed of properly.



## INFORMATION FOR CORRECT DISPOSAL OF THE BATTERIES PURSUANT TO EUROPEAN DIRECTIVE 2006/66/EU and modifications by Directive 2013/56/EU

Replace the batteries when depleted. At the end of their working life, batteries must be disposed of separately from unsorted waste. They must be delivered to appropriate separated waste disposal plants or to dealers that provide a similar service. Separate waste disposal of batteries prevents potential negative effects on the environment and human health resulting from inadequate disposal, and also allows the materials from which it is made to be recovered and recycled in order to achieve significant savings in terms of energy and resources. The separate disposal obligation is underlined by the crossed-out dustbin symbol appearing on the battery. Illegal disposal of the product by the user is subject to administrative penalties as per current regulation.

## CONTROL PANEL

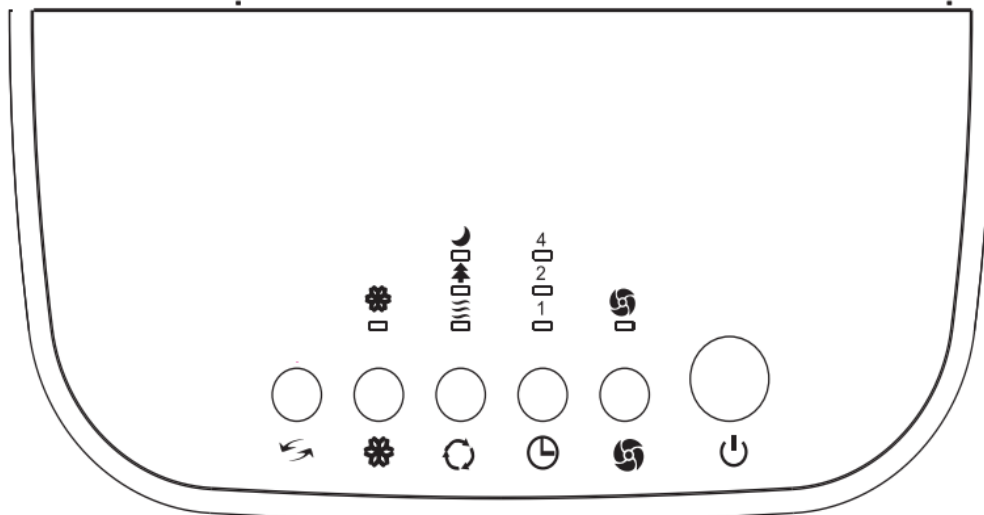

### ON/OFF BUTTON

Press this button on the control panel to turn the unit on or off.  
The default operating mode is low ventilation (red LED) and Normal mode.

### SPEED BUTTON

When the appliance is on, press this button on the panel to select the fan speed, the LED corresponding to the button changes color depending on the selected speed:

Low - Red LED

Medium - Yellow LED

High - Green LED

The SPEED function is not present on the remote control.

### TIMER BUTTON

Timer off function: With the unit on, press this button to select the appliance turn off timer, each press of the button allows you to set the turn off interval from 1 to 7 hours, the LEDs on the control panel will light up based on your selection. Once the selected interval is reached, the unit will turn off automatically.

To disable the Timer setting, press this button several times until all the corresponding LEDs on the unit control panel turn off.

### MODE BUTTON

When the unit is on, press this button on the control panel to select the desired ventilation mode between Normal, Natural and Sleep. The corresponding LEDs on the control panel will light up according to your selection.

On the remote control, by pressing the mode key it is possible to switch from one function to another and then, once the desired function has been reached, with the +/- button it is possible to select the fan speed, the number of hours of the timer, the operating mode.

Each time you press the LEDs on the control panel light up according to your selection.

## COOL BUTTON

Press this button on the control panel to activate the cooling function. When the COOL LED flashes on the control panel, it means that the water level in the tank is below the minimum, therefore it is necessary to add water into the tank.

## SWING BUTTON

Press this button on the control panel or on the remote control to activate the automatic vertical oscillation of the air flaps. To deactivate this function, press this button again. It is possible to manually adjust the flaps horizontally, to direct the air flow where desired.

## FILLING THE WATER TANK

### THE TANK MUST BE FILLED WITH DEMINERALIZED WATER FOR THE APPLIANCE TO OPERATE IN COOLER/HUMIDIFIER MODE.

The water is inserted directly into the rear tank. Before introducing the water, check that there are no water residues inside the water pump, to prevent its leakage.

Fill the tank up to the maximum level marked on the water indicator, without exceeding the water level limit, this could cause water leakage.

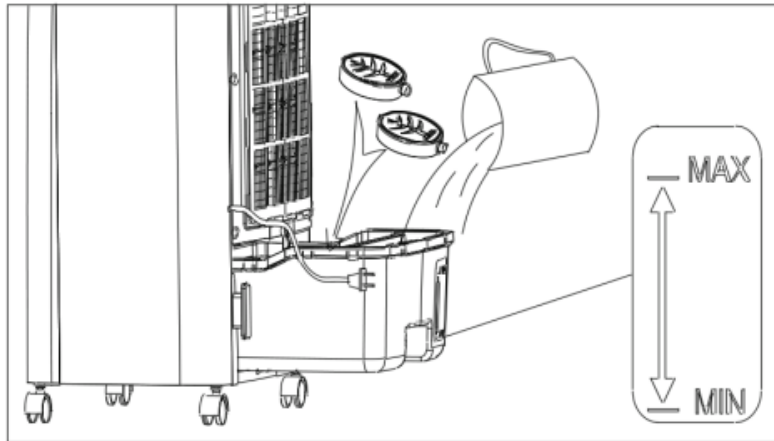

If you wish to keep the water in the tank below room temperature in order to maximize cooling in warmer months, leave the two synthetic ice packs supplied in the freezer until solid, then add them to the water in the tank.

The ice will absorb heat from the water.

With the unit off, place the ice packs directly in the tank in the position shown in the figure, inside the tank there is a special space where to place the ice packs. Make sure that the tank can be pulled out normally.

We recommend continuous use of the ice for optimal cooling capacity.

Ice packs can be used repeatedly.

The first time it is used, you may detect a smell or the water may turn an unusual color: this does not constitute a health risk.

## MAINTENANCE AND STORAGE

### WARNING: ALWAYS UNPLUG THE APPLIANCE BEFORE CLEANING OR MAINTENANCE PROCEDURES. IMPORTANT: DO NOT SUBMERGE THE PRODUCT IN WATER

#### Cleaning the outside surface of the appliance

Use a soft cloth to remove any dust from the product.

If this is not enough, use a soft cloth dampened with water and a mild detergent at a temperature not exceeding 50°C. Let the appliance dry completely before using it.

Do not use corrosive detergents or solvents such as petrol. Do not wash the appliance with water. Do not use oils, chemical substances or other items that may damage the surface to clean it.

Use a vacuum cleaner to remove dust from the air inlet/outlet grilles.

When the appliance is used for a long time, the tank, the tank filter, the honeycomb filter and the dust filter may have accumulated dust, this could affect the air flow and the effect of cooling. It is therefore advisable to clean these parts every two weeks.

### Cleaning the dust filter and the honeycomb filter

Remove the filter assembly by detaching it from the unit by pressing on the opening hook. Once removed, gently remove the honeycomb filter by sliding it under the hooks, remove the dust filter, always sliding it off the hooks. To assemble again, insert the dust filter in its holder and then insert the honeycomb filter.

Make sure all components are perfectly dry and properly installed to avoid damaging them.

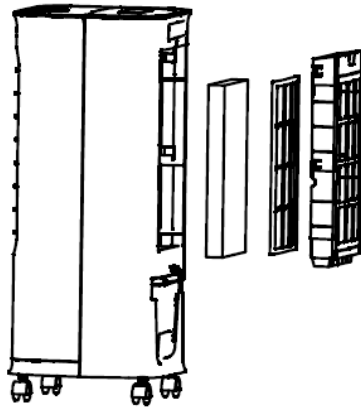

### Cleaning the water tank

1. Rotate the locking hook of the water tank in the horizontal direction, see Pic.1.
  2. Remove the tank following the direction of the arrow as shown in Pic. 2 to have a space for disassembling the pump.
  3. Remove the water pump from the tank by pressing the 2 tabs positioned on the pump (Pic.3), then completely remove the tank for cleaning.
  4. For descaling of the water tank, pour in water and vinegar or an anti-limescale product, leave it on for a sufficient time and rinse with water, then use a soft, dry cloth to clean it.
  5. Reposition the water tank without forgetting to put the pump back into the tank by pressing again on the two tabs positioned on the pump, then hooking it to the tank.
- It is recommended to clean the water tank weekly.

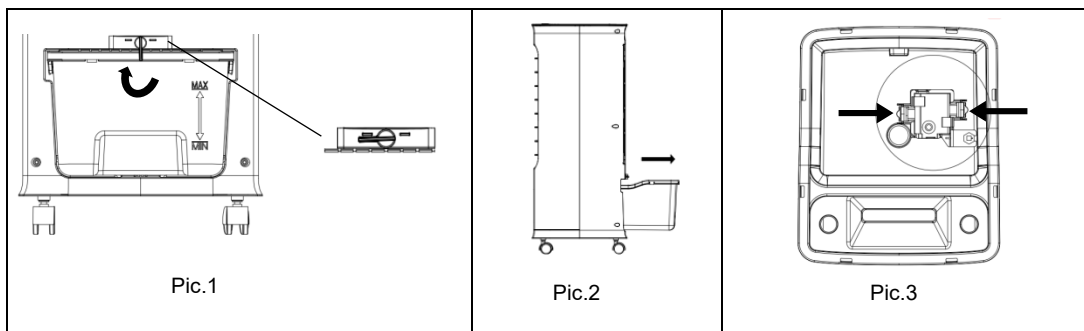

### STORAGE

If the appliance is not used for prolonged periods, disconnect the power cord and store the appliance with this manual in its original packaging, in a cool and dry place.

Before packaging, the honeycomb filter and dust-proof filter should be dry, and there is no water in the tank.



## POSSIBLE OPERATING PROBLEMS AND SOLUTION

If the appliance has any operating anomalies, consult the table below to resolve any anomalies. If they persist, contact an authorized service center to repair the appliance.

PROBLEM	POSSIBLE CAUSE	SOLUTION
The appliance does not work	<p>The power cord is not connected or is not connected properly</p> <p>The appliance is off</p> <p>Internal wiring is loose</p>	<p>Connect it correctly</p> <p>Put the water in the tank</p> <p>Contact a service center</p>
It does not humidify / the water pump makes an abnormal sound	<p>There is no water in the tank or the amount of water is below the minimum water level</p> <p>The hole in the honeycomb filter is blocked</p> <p>The water pump is damaged or the internal connections are missing</p>	<p>After turning off the unit, add water to the tank up to the maximum level indicated</p> <p>Clean the honeycomb filter</p> <p>Contact a service center</p>
Abnormal sound of the unit	<p>The device is not placed on a stable and flat surface</p> <p>There may be dust residues in the appliance</p> <p>The air delivery flaps have not been opened</p> <p>Problem with the motor of the air flaps</p>	<p>Place the device on a flat and stable surface</p> <p>Remove the honeycomb filter and eliminate the accumulation of dust inside the unit</p> <p>Manually open the air delivery flaps</p> <p>Contact a service center</p>



### INFORMATION FOR THE CORRECT DISPOSAL OF THE PRODUCT IN ACCORDANCE WITH EUROPEAN DIRECTIVE 2012/19/EU

This appliance may not be scrapped with domestic waste at the end of its life cycle. We call your attention to the crucial role played by the consumer in the re-use, recycling and other forms of recovery of such waste.

The appliance must be scrapped by a sorted waste disposal centre or by returning it to the retailer (no charge is levied for this service), when you purchase a new equivalent appliance.

Sorted disposal of electric and electronic equipment prevents the negative effects on the environment and human health resulting from improper scrapping, and also allows the materials from which it is made to be recovered and recycled, with significant savings in terms of energy and resources. The sorted disposal requirement is indicated by the crossed waste bin label affixed to the appliance.



improve your life

[www.argoclima.com](http://www.argoclima.com)