



EN

AIR PURIFIER WITH HEPA FILTER AND UVC LAMP

PURY PLUS UVC



OPERATING INSTRUCTIONS

Read the instructions carefully before operating or servicing the air purifier.
Observe all the safety instructions; failure to observe the instructions may lead to accidents and/or damage. Store these instructions in a safe place for future reference.

GENERAL OPERATING AND SAFETY INSTRUCTIONS

- **This appliance is a highly efficient air purifier designed for domestic use only!**
- Use this air purifier only as outlined in this manual. Any other use not recommended by the manufacturer may cause fire, electric shock or malfunctions.
- The unit must be placed in a vertical position at all times.
- Ensure that the available power source conforms to the required voltage and frequency (220-240V ~ 50/60Hz).
- This appliance can be used by children aged from 8 years and above and people with reduced physical, sensory or mental capabilities or lack of experience and knowledge if they have been given supervision or instruction concerning use of the appliance in a safe way and understand the hazards involved.
- Children shall not play with the appliance.
- Cleaning and user maintenance shall not be made by children without supervision.
- Make sure that the plug is fully inserted. Do not use multiple adapters. Do not touch the plug with wet hands. Make sure that the plug is clean.
- This product is not a toy. Children should be adequately supervised to ensure that they do not play with the appliance.
- **Disconnect the main power when the appliance is not in use or during cleaning operations. Keeping the appliance plugged in may cause electric shocks or accidents.**
- To disconnect the appliance, set the switch to OFF and remove the plug from the socket. Pull on the plug only. Do not pull the cord.
- Do not bend, drag or twist the cord, or apply force to remove it. **Do not operate the unit if its cable or plug are damaged; doing so can cause fires or electric shock.** If the power cord is damaged, it must be replaced by a service centre.

- Do not place the cable under carpets, inside furniture or under equipment that emits heat such as radiators and stoves.
- **Do not place heavy objects on the appliance.**
- **Do not use the appliance on unstable or sloping surfaces.**
- The air purifier must be placed **at least 50 cm** from the wall or from other obstacles, to ensure proper heat dissipation.
- **Close all open windows to maximise air purification efficiency.**
- **Do not insert objects or sharp instruments into the air outlet grille.**
- **Do not cover the air intake and outlet grilles in any way.**

WARNING!

This appliance contains a UV-C lamp; do not stare at the light source.

Improper use of the appliance or damage to the housing can result in the release of dangerous radiation UV-C.

UV-C radiation can, even in small doses, cause damage to the eyes and skin.

Obviously damaged devices must not be put into operation.

Replacement of the UV-C emitter by the user is not permitted.

WARNING!

Before proceeding with maintenance and cleaning, disconnect the appliance from the power supply.

If the power supply cable is damaged, it must be replaced by the manufacturer or its technical assistance service or in any case by a person with similar qualifications, in order to prevent any risk.

WARNING!

In the event of an anomaly, switch the appliance off and unplug it immediately. Do not dismantle, repair or modify this product freely. In the event of a malfunction, contact the after-sales service centre directly.

- Do not immerse the power cord, plug or any other part of the appliance in water or other liquids.
- Do not expose the air purifier to direct sunlight.
- Do not use the appliance outdoors.
- Keep the appliance well away from sources of heat which could cause plastic parts to become warped.
- Do not spray insecticides, oils or paints near the appliance; doing so may damage its plastic parts or start a fire.
- **Keep flammable gases and oils away from the appliance!**
- **Do not move the appliance while it is operating, as this may cause malfunctions.**

DESCRIPTION OF PARTS

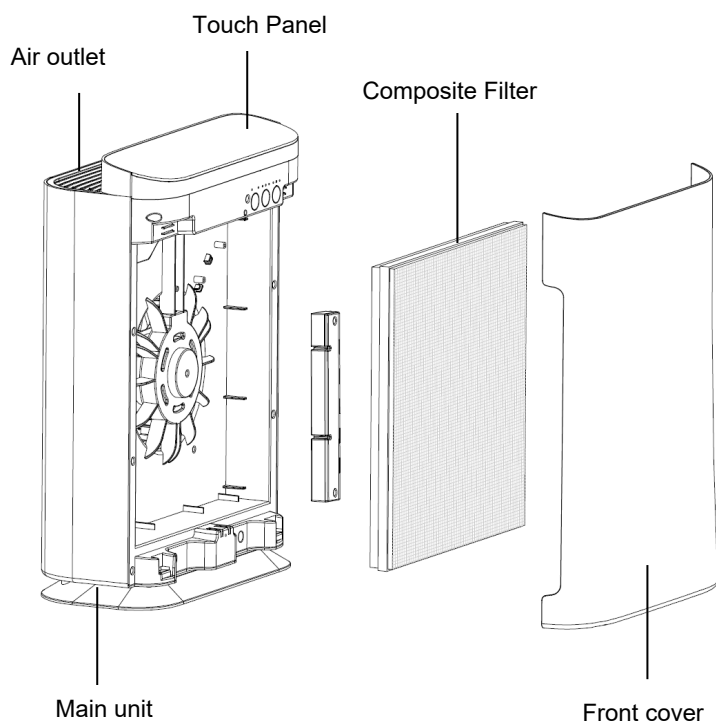

MULTISTAGE PURIFICATION SYSTEM

This air purifier is equipped with an effective multistage purification system, made possible by a multilayer filter, consisting of:

- 1. PRE-FILTER:** Filter the largest dust and other allergens particles, which consequently allows for extending the life of the HEPA filter.
- 2. ACTIVATED CARBON FILTER:** absorb odors, formaldehyde, benzene and other harmful gases
- 3. HEPA FILTER 13:** It can filter particles with a diameter above 0.3 microns and effectively eliminates pollen, smoke and other allergens.

To it is added the action of:

- 4. UVC LAMP:** Performs an effective sterilization function, kill virus and germs up to 99,97%
- 5. IONIZER:** It generates negative ions, capable of counteracting the positive ions that are formed in indoor environments due to household appliances such as television and radio, improving air quality and generating a feeling of general well-being.

INSTRUCTIONS BEFORE USING THE AIR PURIFIER

Before using the air purifier for first time, perform the following operations:

1. Carefully remove the air purifier from the box and the plastic bag
2. Place the appliance on a flat and stable surface
3. Remove the filter and remove the plastic bags that protect it

4. Connect the unit to the power supply, with respect to the voltage on the product data plate (220-240V): you will hear a sound signal

When moving the air purifier, always lift unit by the carrying handle located on the back.

CONTROL PANEL AND DISPLAY

CONTROL PANEL

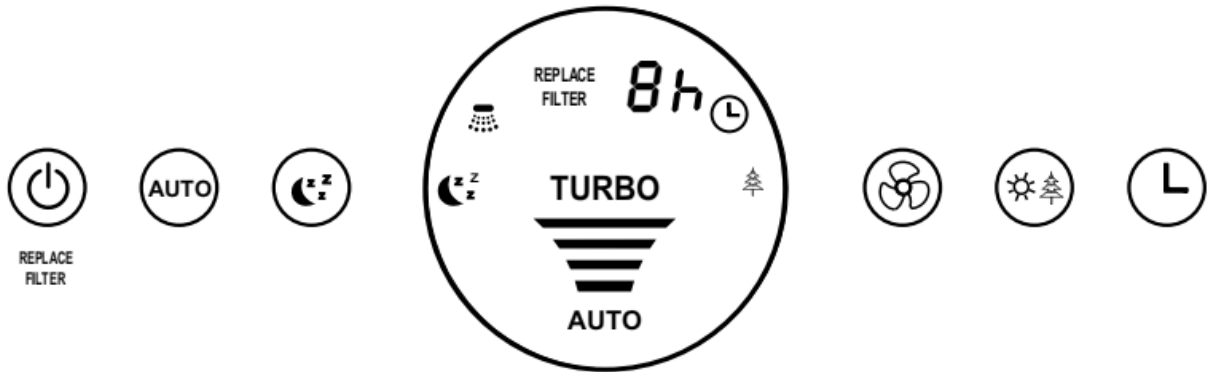

DISPLAY

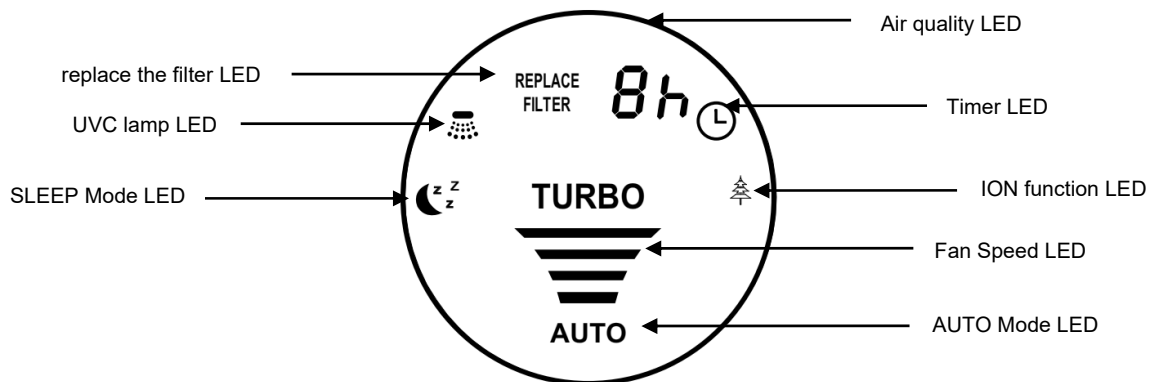

FAN SPEED LED

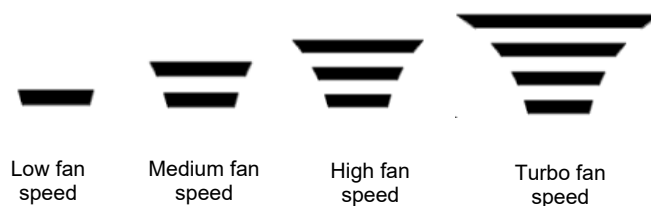

ON/OFF and RESET FILTER BUTTON

Touch this button to turn on or off the unit.

Touch this button for 3-5 seconds to activate the Reset filter function, after having replaced the filter.

AUTO BUTTON

Touch this button to switch on or switch off the AUTO mode: when this mode is activated, the LED on the display turns on (AUTO) and the appliance adjusts the ventilation speed automatically according to the air quality detected by the quality sensor integrated and indicated by the color of the ring on the display:

LIGHT BLUE - Good air quality (automatic ventilation 1, minimum)

YELLOW - Medium air quality (automatic ventilation 2, medium)

ORANGE - Poor air quality (automatic ventilation 3, high)

RED - Bad air quality (automatic ventilation 4, Turbo)

If the button  is pressed, the AUTO mode is deactivated: it is therefore possible to manually adjust the fan speed.



SLEEP BUTTON

Touch this button to activate the Sleep mode, the indicator on the display will flash for 10 seconds, after which all the LEDs, including the one relating to the Sleep mode, will turn off. The appliance will operate at low ventilation speed. To deactivate the Sleep function, touch any key on the panel, including the Sleep key.





FAN SPEED BUTTON

Touch this button to adjust the fan speed (low, medium, high, turbo).



UVC AND ION BUTTON

Touch this button once to turn on the UVC lamp (the icon  will appear on display), press twice to turn on the Ionization (the icon  will appear on display), press three times to turn off the UVC lamp, and press four times to turn off the Ionization: the corresponding LEDs disappear from the display.



TIMER BUTTON

Touch this button to adjust the operating timer from 1 to 9 hours: the appliance stops automatically according to the set time.

AIR QUALITY LED

The device is equipped with an air quality sensor, which shows the level detected in the room through the LED ring on the display, color can change as follows:

LIGHT BLUE - Good air quality (minimum automatic ventilation)

YELLOW - Medium air quality (medium automatic ventilation)

ORANGE - Poor air quality (high ventilation speed)

RED - Bad air quality (Turbo ventilation)

REPLACEMENT OF COMPOSITE FILTER

When the "REPLACE FILTER" LED lights up on the display, it is necessary to replace the composite filter, available at authorized service center.

To replace the filter, follow the instructions below:

Turn off the appliance and follow the instructions to replace the filter:

1. Remove the front panel from the top
2. Remove the composite filter by pulling the two tabs
3. Insert the new filter, taking care that the two tabs are positioned correctly outwards
4. Attach the pre-filter to the composite filter
5. Replace the front panel
6. Press and hold the Power button  for 3-5 seconds to reset the filter

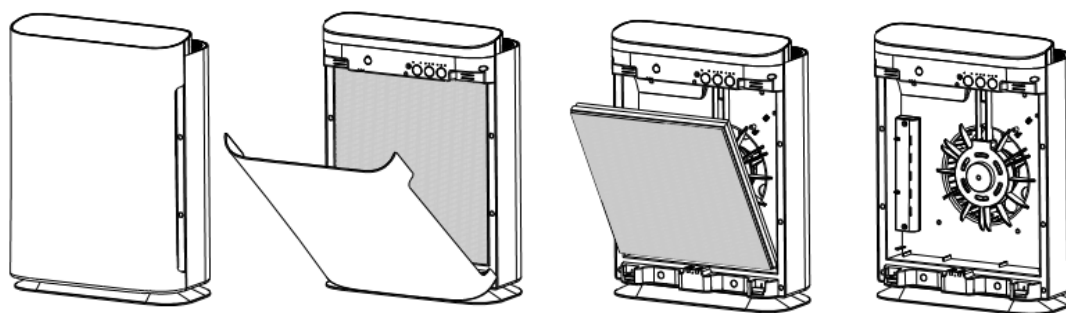

The average life of the composite filter is approximately 6 months.

CLEANING AND MAINTENANCE

⚠ Warning

Always pull the air purifier's plug out of the power socket before cleaning it, to prevent electric shocks or malfunctions.

⚠ Warning

Do not wet or immerse the air purifier in water, as this may cause electric shocks.

Use a damp and soft cloth to clean the outer surface of the air purifier.

Do not use solvents, petrol, xylene, talcum powder or brushes to clean the unit: these may damage the surface or colour of the casing.

Cleaning the casing

Use a damp and soft cloth to clean the outer surface of the appliance.

Do not use excessively hot water, solvents, petrol or other aggressive chemical compounds, talcum powder or brushes: these may damage the surface or colour of the casing.

Remove stains using lukewarm water with a little neutral detergent.

Do not pour water onto the air purifier to clean it, as this may damage the internal components or cause a short circuit.

CLEANING THE FILTER

The filter should be cleaned once a month, or more frequently depending on the conditions of the environment.

Clean the filter with a vacuum cleaner to remove dust and dirt particles.

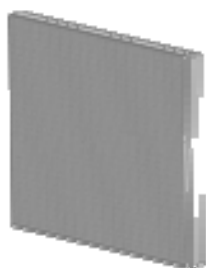

Composite Filter

Do not clean the composite filter with water, only the pre-filter can be washed with water, before fixing it on the composite filter make sure it is completely dry.



INFORMATION ON CORRECT DISPOSAL OF THE PRODUCT ACCORDING TO EUROPEAN DIRECTIVE 2012/19/EU ON THE DISPOSAL OF ELECTRICAL AND ELECTRONIC WASTE MATERIALS'

This appliance must not be scrapped with domestic waste at the end of its life cycle. We call your attention to the crucial role played by the consumer in the reuse, recycling and other forms of recovery of such waste.

The dismantled appliance, with its components collected separately, must be delivered to the local waste disposal facility or returned to the dealer free of charge when purchasing a new equivalent appliance.

Sorted disposal of electric and electronic equipment prevents potentially negative consequences on the environment and human health due to improper scrapping, and also allows the constituent materials to be recovered and recycled, with significant savings in terms of energy and resources.

The sorted disposal requirement is indicated by the crossed dustbin symbol affixed to the product.



improve your life

www.argoclima.com