



improve your life

CE

EN

POLIFEMO KIRK

EVAPORATIVE AIR COOLER



OPERATING INSTRUCTIONS

Read the instructions carefully before operating the appliance or carrying out maintenance operations. Observe all the safety instructions; failure to observe the instructions may lead to accidents and/or damage. Keep these instructions in a safe place for future reference.

GENERAL OPERATING AND SAFETY INSTRUCTIONS

- Only use this appliance as described in this manual. Any other use not recommended by the manufacturer may cause fire, electric shock or injury to people.
- Do not use this appliance outdoors, this product is for indoor use only.
- Make sure that the type of mains power complies with the electrical requirements of the appliance (220-240V~/50-60 Hz).
- It is necessary to use a qualified socket that has been checked, and that meets the requirements.
- This appliance can be used by children aged from 8 years and above and people with reduced physical, sensory or mental capabilities or lack of experience and knowledge if they have been given supervision or instruction concerning use of the appliance in a safe way and understand the hazards involved.
- Cleaning and user maintenance shall not be made by children without supervision.
- This product is not a toy. Children should be adequately supervised to ensure that they do not play with the appliance.
- **Do not use the appliance if the cord or plug is damaged.** If the power supply cable is damaged, it must be replaced by the manufacturer or its technical assistance service, or in any case by a person with similar qualifications, in order to prevent any risk.
- The appliance must be installed in accordance with national wiring regulations.
- Disconnect the mains power when the appliance is not used or for cleaning operations.
- Unplug the appliance during filling and cleaning.
- Do not touch the power plug with wet hands, there is a danger of electric shock.
- When unplugging the power cord, do not pull on the cord.
- Do not bend the power cord or place heavy objects on it. Do not use extension cables.
- Do not place the appliance under a power socket, do not use the appliance in a bathroom or near a swimming pool.
- During use, make sure that the power cord plug is free from foreign bodies and fully insert the plug into the power outlet.

- In case of anomalies, switch off the appliance immediately, do not try to repair it, and take it to the local technical assistance center.
- Do not disassemble or replace the parts by yourself, this may affect the safety of the product.
- If, during operation, an abnormal smell or sound comes out of the product, immediately turn off the appliance and disconnect the power supply.
- Do not block the air inlet and outlet grilles and do not insert objects, they could cause leaks, short circuits and damage to the product.
- Do not expose the cooler to direct sunlight, because the color of the materials could be altered and the appliance overheating.
- **Do not use insecticides, oils, detergents, flammable or explosive sprays or spray paints around the appliance; do not use aggressive chemical detergents to clean the casing: this could damage the finish and color.**
- Do not spill water on the product: risk of short circuit and damage to the appliance.
- Be aware that high humidity levels may encourage the growth of biological organisms in the environment.
- Do not permit the area around the humidifier to become damp or wet. If dampness occurs, turn the output of the humidifier down. If the humidifier output volume cannot be turned down, use the humidifier intermittently. Do not allow absorbent materials, such as carpeting, curtains, drapes, or tablecloths, to become damp.
- Never leave water in the water tank when the appliance is not in use.
- Empty and clean the appliance before storage. Clean the appliance before next use.
- Do not leave the air flow directed towards a child for a long time: it is not healthy.
- After adding water to the tank, do not tilt or bump the product when placing or moving it, to avoid splashing. If the tank has been emptied but there is water in the machine, unplug it immediately and wait 24 hours before turning it on.
- The water level in the water tank must not exceed the maximum level line. When the cooling and humidification functions are activated, the water level in the water tank must not be below the minimum level line.
- When the tank is full of water, push gently to move the product, otherwise

the water in the water tank may flow out. After making sure there is no water in the tank, lift the whole machine.

- During humidification, it is strictly forbidden to disassemble and assemble the filter and the evaporative panel, as water drops could escape from the air outlet.

DESCRIPTION OF THE APPLIANCE

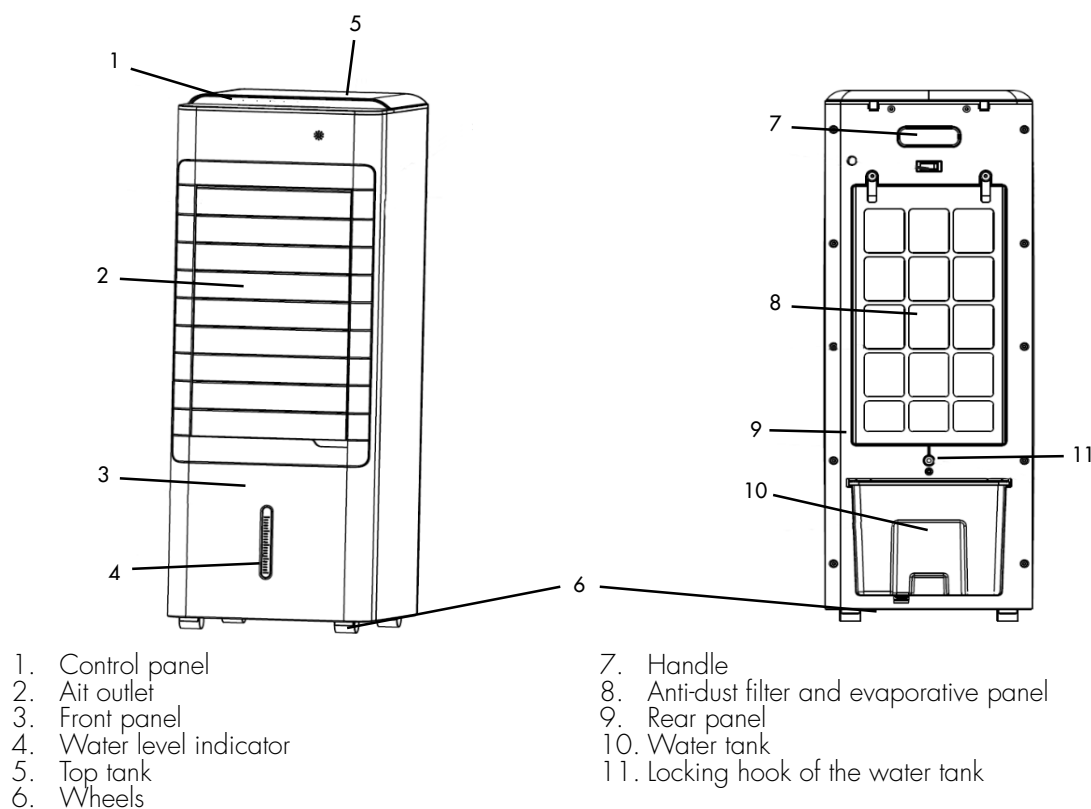

HOW TO USE THE APPLIANCE

The appliance does not require installation.

Before using the appliance, it is necessary to assemble the 4 wheels, fixing them in the holes located under the unit.

Place the unit on a flat and stable surface and connect the power cable to an appropriate socket (220-240V~50/60Hz): the unit can be started by pressing the ON/OFF key, the unit it will make a sound.

When moving it, use the handle on the back.

Do not use this cooler in an area with high humidity, dust or temperatures above 40°C.

This product can be used, with 3 modes (Normal, Natural and Sleep) and 3 possible fan speeds (low, medium, high), both as a fan and as a cooler/humidifier: in this case, fill the rear tank with water demineralised, without exceeding the maximum limit indicated on it.

During operation, it is advisable to check the minimum water level, which can be viewed on the indicator located on the front of the appliance, to make sure that there is sufficient water for the cooling/humidification function, thus avoiding damaging the water pump.

The fan draws in the air from the room and passes it through the anti-dust filter and the evaporative panel, which is kept constantly humidified thanks to a system that draws water from the tank and sprays it on the panel. The warm incoming air causes part of the water soaked in the panel to evaporate and is sent back into a cooler environment, producing a decrease in the perceived temperature.

FUNCTION CONTROLS

BY REMOTE CONTROLLER

How to insert batteries into the remote controller

- Open the rear door.
- Remove the battery already inserted in the remote controller and remove the transparent protective film applied to the battery.
- Insert the supplied button cell battery (CR2025/3V), compliant with Battery Directive no.2006/66/EC and amendments by Directive 2013/56/EC into the remote controller, respecting the indicated polarity.
- Close the door.
- Point the remote controller at the receiver on the air conditioner.
- The remote controller must be placed within 5 meters of the unit.
- Make sure there are no obstacles between the remote and the receiver.
- Do not drop or throw the remote controller.
- Do not put the remote controller under strong sunlight or under heating devices and also under other heat sources.
- Remove the battery from the remote control when it is not used for a long time.
- If there is no sound and the transmission symbol on the display screen does not flash, the battery needs to be replaced.
- Used batteries must be disposed of properly.

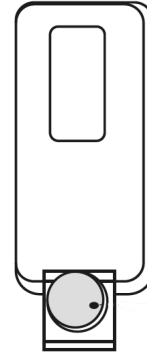

WARNINGS FOR BATTERIES

- Batteries should not be exposed to heat sources such as fire, sun or similar sources;
- remove the batteries if they start to heat up or you know you will not use the appliance for a long time the batteries must be installed correctly in the battery compartment;
- when removing the batteries because they are at the end of their life or damaged, comply with the national regulations in force for disposal (shown below);
- In the event of a battery fluid leak, remove all batteries, taking care not to let the leaked fluid come into contact with skin or clothes.

If liquid from the battery gets on your skin or clothing, wash the skin with water immediately. Before inserting new batteries, thoroughly clean the battery compartment with a dry paper towel, or follow the battery manufacturer's recommendations for cleaning. Only use batteries of the same size and type.

Caution: Danger of explosion if battery is replaced by a type other than that specified.

Improper use of batteries can cause them to leak, overheat, or explode. This liquid is corrosive and can be toxic. It can cause skin and eye burns, and is harmful to ingest.

To reduce the risk of injury:

- Keep batteries out of the reach of children.
- Do not heat, open, puncture, cut or throw batteries into fire.
- Do not mix old and new batteries or batteries of different types
- Do not leave metal objects that could come into contact with the battery terminals and therefore could heat up and/or cause burns.



INFORMATION FOR THE CORRECT DISPOSAL OF BATTERIES IN ACCORDANCE WITH EUROPEAN DIRECTIVE 2006/66/EC and amendments Directive 2013/56/EU

Replace batteries when they are depleted. At the end of their life, batteries must be disposed of separately from unsorted waste. They must be taken to designated recycling centres or returned to a retailer providing this service. Separate disposal of batteries prevents potential negative effects on the environment and human health due to inadequate disposal, and also allows for recovering and recycling their constituent materials, resulting in significant savings in terms of energy and resources. The separate disposal obligation is underlined by the crossed-out dustbin symbol appearing on the battery. Illegal disposal of the product by the user implies administrative sanctions applied as per current regulations.

FOR OPTIMAL REMOTE CONTROLLER OPERATION, POINT THE TRANSMITTER HEAD TOWARDS THE RECEIVER ON THE APPLIANCE.

CONTROL BY REMOTE CONTROLLER

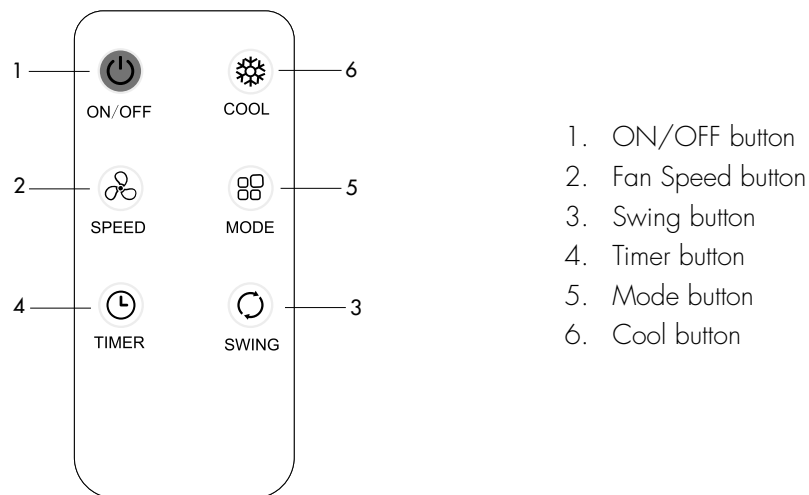

CONTROL BY CONTROL PANEL

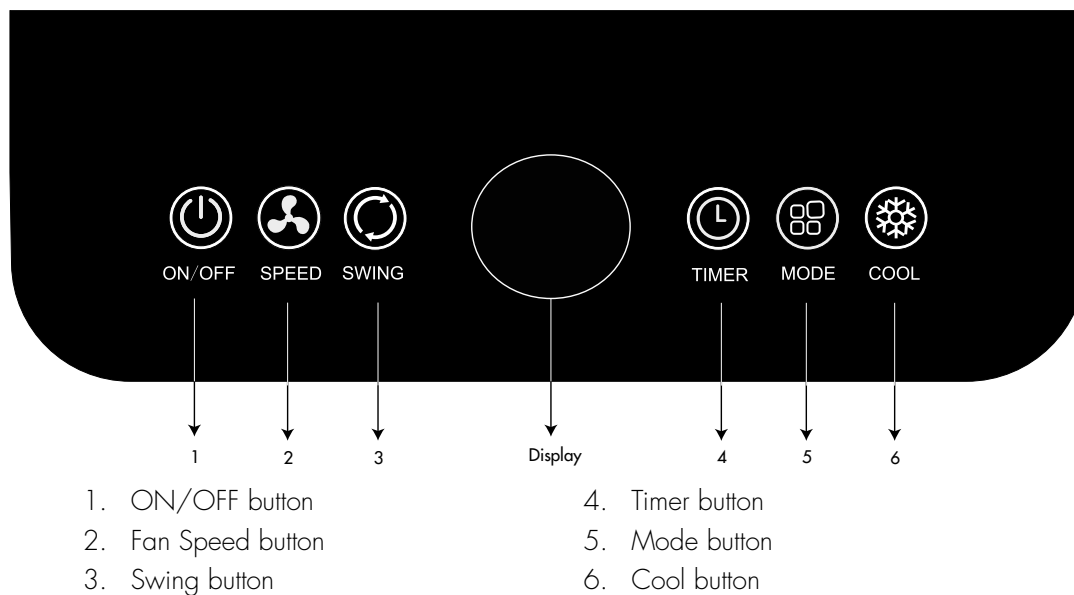

FUNCTION OF THE BUTTONS ON THE REMOTE CONTROLLER AND CONTROL PANEL

1. ON/OFF BUTTON

Press this button on the remote controller or control panel to turn the unit on or off. After pressing this button, the appliance emits a sound signal and goes into stand-by mode, press it again to start the cooler operation. The corresponding icon  is always on during operation.

2. FAN SPEED BUTTON

Press this button on the remote controller or on the control panel to adjust the fan speed in the following circular sequence: Low - Medium - High.

The icon  turns on, while the display, depending on the speed selected, will show:

- Low fan speed F1
- Medium ventilation speed F2
- High fan speed F3

When the appliance is switched on, the default fan speed is Medium.

3. SWING BUTTON

Press this button on the remote controller to activate the vertical swing of the air flaps. The icon  lights up on the display.

Press this button again to stop the automatic swing, fixing the air jet where desired. The horizontal flaps, on the other hand, can only be directed manually.

Press this button again to turn off the auto swing function

4. TIMER BUTTON

When the unit is on, press the Timer button on the control panel or remote controller to set the time for the unit to turn off. Each time the key is pressed, the selection interval will increase by 1 hour up to a maximum of 12 hours. The set switch-off interval will be shown on the display for about 3 seconds, then the room temperature will be shown.

To display the interval after which the appliance will switch off, press the Timer button once, the remaining time will flash on the display for about 3 seconds, then the room temperature will be displayed again.

When the Timer function is activated, the icon  stays on on the display

5. MODE BUTTON

Press this button on the control panel or remote controller to select the operating mode in the following circular sequence: Normal, Natural, Sleep

- Normal: The icon  lights up on the control panel
- Natural: the icon  lights up on the control panel
- Sleep: The icon  lights up on the control panel

6. COOL BUTTON

Press this button on the control panel or remote control to activate the cool/humidify function.

The icon  lights up on the control panel

During operation, it is advisable to check the minimum water level, which can be viewed on the indicator located on the front of the appliance, to make sure that there is sufficient water for the cooling/humidification function, thus avoiding damaging the pump.

FILLING THE WATER TANK

IT IS NECESSARY TO FILL THE TANK WITH DEMINERALIZED WATER TO MAKE THE APPLIANCE WORK IN COOLING MODE.

The water goes directly into the rear tank. Before introducing the water, check that there are no water residues inside the water pump, to prevent it from leaking.

Fill the tank up to the maximum level marked on the water indicator, without exceeding the limit, this could cause it to overflow.

If you want to keep the tank water temperature below room temperature for a long time, in order to favor cooling in the hottest season, add the synthetic ice tablets supplied to the tank water, after having left them in the freezer for the time necessary for their complete consolidation (about 4 hours). Ice absorbs heat from water.

With the unit off, place the ice packs directly into the tank. Make sure the tank can be pulled out normally.

Continuous use of ice is recommended to optimize cooling capacity.

Ice tablets can be used repeatedly.

It is possible that on first use you smell a scent or the water takes on a particular colour: there are no health risks.

CARE AND MAINTENANCE

WARNING!

Always unplug the appliance before cleaning or maintenance procedures.

1. Cleaning the dust filter and the honeycomb filter

The filter must be checked at least once every two weeks. Operation with dirty or clogged filters always causes a reduction in the efficiency of the cooler and can cause serious problems.

To remove the filter assembly, unscrew the two screws located on the back of the unit. Once removed, gently remove the honeycomb filter then remove the anti-dust filter built into the grille.

Gently clean the dust filter with a neutral detergent at a temperature below 40°C, rinse and leave to dry completely in a cool, dry place, avoiding direct exposure to the sun. The honeycomb panel, on the other hand, should be cleaned delicately with a vacuum cleaner or a soft brush, avoiding getting it wet.

Make sure that all components are perfectly dry and that they are correctly installed to avoid damaging them.

When the appliance is used for a long time, the tank, honeycomb filter and dust filter may have accumulations of dust, which may affect the airflow and cooling effect.



2. Cleaning of water tank

The water tank cannot be removed, so clean it without taking it out.

3. Cleaning of casing

Use a soft cloth to remove dust from the product. If this is not enough, use a soft cloth moistened with water and neutral detergent at a temperature below 40°C.

Let the appliance dry completely before using it.

Do not apply corrosive cleaners or solvents such as benzene. Do not wash the appliance with water.

When cleaning, do not use oils, chemicals or other objects that could damage the surface.

4. Storage

During periods of non-use, unplug the power cord and store the appliance together with this manual in the original box in a cool, well-ventilated place.

Before packing, the water tank, honeycomb panel and dust filter must be perfectly dry and there should be no water in the tank.

Do not place heavy objects on the top surface and possibly protect the appliance with a plastic sheet.

5. For maximum safety, periodically check the condition of the power cable; if it is damaged by use, for replacement, contact an authorized Service Centre.

POSSIBLE OPERATING PROBLEMS AND SOLUTION

If the appliance has any malfunctions, consult the table below for possible solutions.
If malfunctions persist, contact an authorized service center to check the appliance.

Problem	Possible cause	Solution
The appliance does not work	The power cord is not connected or is not connected properly to the electrical outlet The Off Timer may have been activated	Check that the power cord is properly plugged into the electrical outlet Check that the Off Timer function is not active
Difficult to move the product	There may be an obstacle or object blocking the wheels The wheels could be damaged	Remove any obstacles or objects that may block the wheels Contact an authorized service center to replace the wheels
The appliance does not humidify	The water pump is not working properly The water level in the tank could be below the minimum level	Check the water pump operation Add water to the tank up to the minimum level indicated



INFORMATION FOR THE CORRECT DISPOSAL OF THE PRODUCT IN ACCORDANCE WITH EUROPEAN DIRECTIVE 2012/19/EU

This appliance may not be scrapped with domestic waste at the end of its life cycle. We call your attention to the crucial role played by the consumer in the re-use, recycling and other forms of recovery of such waste.

The appliance must be scrapped by a sorted waste disposal centre or by returning it to the retailer (no charge is levied for this service), when you purchase a new equivalent appliance.

Sorted disposal of electric and electronic equipment prevents the negative effects on the environment and human health resulting from improper scrapping, and also allows the materials from which it is made to be recovered and recycled, with significant savings in terms of energy and resources. The sorted disposal requirement is indicated by the crossed waste bin label affixed to the appliance.



improve your life

www.argoclima.com

Argoclima assumes no responsibility for any errors or inaccuracies in the content of this manual and reserves the right to make to this, at any time and without notice, any changes deemed appropriate for any technical or commercial need.