



improve your life

## MULTI SPLIT AIR CONDITIONERS – R32 - WIFI

### **USER and INSTALLATION MANUAL**

---

#### **OUTDOOR UNITS**



ARGO DUAL 14 DCI R32  
ARGO DUAL 18 DCI R32  
ARGO TRIAL 21 DCI R32  
ARGO TRIAL 24 DCI R32  
ARGO QUADRI 28 DCI R32  
ARGO QUADRI 36 DCI R32  
ARGO PENTA 42 DCI R32

**Please read this manual carefully before installing and using the air conditioner, and retain for future reference.**

# Contents

<b>Information for use</b>	
The Refrigerant	30
Precautions for use	31
Description of components	33
<b>Installation instructions</b>	
Installation diagrams	34
Choosing a location for installation	36
Electrical connection requirements	36
<b>Installation</b>	
Outdoor unit installation	39
Vacuum pump	40
<b>Testing and operation</b>	
Post-installation checks	42
Safety operation of flammable refrigerant	42
Test operation	44
<b>Appendices</b>	
Piping configuration	44
Procedure for extending the piping	45
Warnings for the refrigeration system specialist	46

## **INFORMATION FOR CORRECT DISPOSAL OF THE PRODUCT IN ACCORDANCE WITH THE EUROPEAN DIRECTIVE 2012/19/EU**



At the end of its working life this equipment must not be disposed of as an household waste. It must be taken to special local community waste collection centres or to a dealer providing this service. Disposing of electrical and electronic equipment separately avoids possible negative effects on the environment and human health deriving from an inappropriate disposal and enables its components to be recovered and recycled to obtain significant savings in energy and resources. In order to underline the duty to dispose of this equipment separately, the product is marked with a crossed-out dustbin.

This product is not intended for use by persons (including children) with reduced physical, sensory or mental abilities or who do not possess adequate experience and knowledge, unless they are supervised or instructed in the use of the product. by a person responsible for their safety. Children must be supervised to ensure that they do not play with the appliance. If you need to install, move or service the air conditioner, please contact your dealer or local service center for the procedure first. The air conditioner must be installed, moved or maintained by authorized personnel. Failure to do so could result in serious damage, personal injury or death.

Radio equipment operating frequency band (s): 2400 MHz-2483 MHz  
Maximum radio frequency power transmitted at the operating band frequencies of the radio equipment: 20 dBm.

## **REQUIREMENTS FOR INSTALLATION AND MAINTENANCE PERSONNEL**

**All personnel who carry out installation and / or maintenance operations on the units must be equipped with PEF (European Refrigerators License) as required by the D.P.R. n. 146/2018 implementing Regulation (EU) no. 517/2014. If another technician is required to maintain and repair the equipment, this will need to be supervised by the person who is qualified to use flammable refrigerants.**

**The repair must be performed according to the methodology indicated by the manufacturer of the equipment.**

**If you need to install, move or service the air conditioner, please contact your dealer or local service center for the procedure first. The air conditioner must be installed, moved or maintained by authorized personnel. Failure to do so could result in serious damage, personal injury or death.**

## Spiegazione dei simboli



This symbol indicates the possibility of death or serious injury.



This symbol indicates the possibility of injury or damage to property.

**NOTICE**

Indicates important but not hazard-related information, used to indicate risk of property damage.



Indicates a hazard generally marked with the word **WARNING** or **CAUTION**.

## Exception Clauses

Manufacturer will bear no responsibilities when personal injury or property loss is caused by the following reasons.

1. Damage the product due to improper use or misuse of the product;
2. Alter, change, maintain or use the product with other equipment without abiding by the instruction manual of manufacturer;
3. After verification, the defect of product is directly caused by corrosive gas;
4. After verification, the defects are due to improper operation during transportation of product;
5. Operate, repair, maintain the unit without abiding by instruction manual or related regulations;
6. After verification, the problem or dispute is caused by the quality specification or performance of parts and components that produced by other manufacturers;
7. The damage is caused by natural calamities, bad using environment or force majeure.

## INFORMATION FOR USE

### The Refrigerant R32



Appliance is filled with flammable gas R32.



Before installing and using the appliance, read the owner manual.



Before installing the appliance, read the installation manual.



Any repairs you need, contact the nearest authorized Service Centre and strictly follow manufacturer's Service Manual.

### The Refrigerant R32

- To realize the function of the air conditioner unit, a special refrigerant circulates in the system. The refrigerant is the fluoride R32 = GWP (Global warming potential) 675. This refrigerant is flammable and inodorous. It can lead to explosions under certain conditions, however the flammability of this refrigerant is very low and it can be ignited only by fire.
- Compared to other common refrigerants, R32 is a non-polluting refrigerant with no harm to the ozoneosphere and a no effect upon the greenhouse effect. R32 has very good thermodynamic features which lead to a really high energy efficiency. The units therefore need less filling.

### Warning:

Do not try to accelerate the defrosting process or to clean the appliance in different ways other than those recommended by the manufacturer. Should repair be necessary, contact your nearest authorized Service Centre. Any repairs carried out by unqualified personnel may be dangerous. The appliance has to be stored in a room that doesn't have any continuously operating ignition sources. (for example: open flames, an operating gas appliance or an operating electric heater.) Do not pierce or burn. Appliance has to be installed, used and stored in a room with a floor area larger than XX m<sup>2</sup>. (Refer to table "a" in the section "Flammable refrigerant safety operations"). The appliance contains flammable R32 gas. Attention refrigerants have no smell.

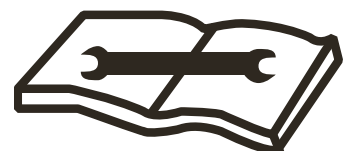

## INFORMATION FOR USE





### Precautions for use



#### WARNING

- This product is not a toy. Children of less than 3 years should be kept away unless continuously supervised.
- This device is not intended for persons (including children aged from 8 years and above) with reduced physical, sensory or mental capabilities, or without the necessary experience and knowledge, unless they have received the necessary supervision or instruction concerning use of the appliance by a person responsible for their safety.
- Children aged from 3 and less than 8 years shall only switch on/off the appliance provided that it has been placed or installed in its intended normal operating position and they have been given instruction concerning use of the appliance in a safe way and understand the hazards involved. Children aged from 3 years and less than 8 years shall not plug in, regulate and clean the appliance or perform user maintenance.
- To prevent the risk of fire, do not connect the air conditioner to a multifunction socket.
- Always disconnect the power before servicing or cleaning the unit.
- To prevent the risk of electric shock or malfunction, do not spray water on the indoor unit.
- Do not spill water on the remote control.
- To prevent the risk of electrical shock or damage, do not attempt to repair the air conditioner yourself. After performing the checks in the troubleshooting section, contact an authorised service centre.
- Do not obstruct the inlet or outlet. Otherwise, a fault may occur.
- Contact a qualified technician if it is necessary to move the air conditioner to another location.
- Do not climb on or place heavy objects on the top panel of the outdoor unit. Otherwise, there is a risk of damage or personal injury.
- Do not put fingers or other objects in the air inlet/outlet grilles. Otherwise, there is a risk of damage or personal injury.
- The air conditioner must be properly earthed. Improper earthing can cause electrical shock.
- Always install a circuit breaker. Otherwise, a fault may occur.
- The unit must be installed and serviced by a qualified technician. Otherwise, there is a risk of damage or personal injury.

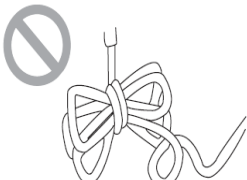
- Frequency band(s) in which the radio equipment operates 2400MHz-2483.5MHz.
- Maximum radio-frequency power transmitted in the frequency band(s) in which the radio equipment operates: 20dBm.

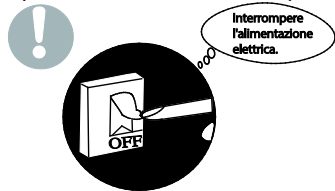
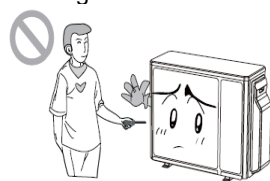
<b>WARNING</b>		
<p>★ In case of smoke or burning smell, turn off the power supply and contact the service center.</p>  <p>If the problem persists, the unit could be damaged and cause electrical shock or fire.</p>	<p>★ It is necessary that power supply adopts the special circuit with protection through an air switch and ensure it has sufficient capacity. The unit switches on or off automatically according to user needs: do not turn on or turn off the device frequently otherwise it could suffer harmful effects.</p>	<p>★ Do not cut or damage the power cords and control cables. If the power cable and the cable of the control signal are damaged, they must be replaced by a professional technician.</p> 
<p>★ The power supply must be equipped with a special circuit to prevent fire.</p>  <p>Otherwise, it may result in fire or electric shock.</p>	<p>★ Disconnect the power supply if the air conditioner is not used for a long time</p>  <p>Otherwise, the accumulation of dust can cause overheating.</p>	<p>★ Do not damage the power cord or use an unauthorized cable.</p>  <p>Otherwise, it may cause overheating or fire.</p>
<p>★ When cleaning the unit, stop operation and turn off the power.</p>  <p>Otherwise, may occur electric shock or damage.</p>	<p>★ The voltage rating of this product is 220 - 240V, 50Hz. The compressor vibrates strongly if the voltage is too low, causing damage to the cooling system. The electrical components are easily damaged if the voltage is too high.</p>	<p>★ Do not attempt to repair the air conditioner yourself.</p> <p>An improper repair can cause fire or electric shock. For this reason, it is advisable to contact a service center for repairs.</p>
<p>★ Check if the installed media is sufficiently stable.</p> <p>If damaged, it can cause the equipment to fall and cause injury.</p>	<p>★ Do not climb on the outdoor unit or place anything on it.</p> <p>The falling of the outdoor unit can be dangerous</p>	<p>★ Earthing: The unit must be properly grounded. The cable grounding must be connected with the appropriate device in the building.</p> 

## Description of components

### Outdoor unit

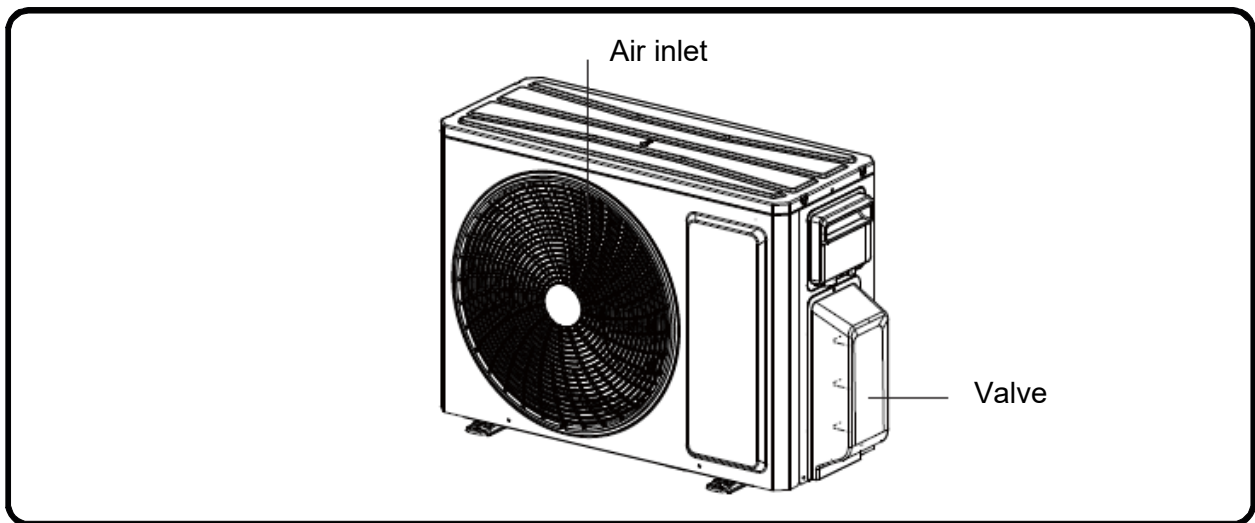

### Operating temperature range

The operating temperature range (outdoor temperature) in cooling : from  $-15^{\circ}\text{C}$ ~ to  $+43^{\circ}\text{C}$ .  
The operating temperature range (outdoor temperature) in heating : from  $-15^{\circ}\text{C}$ ~ a  $+24^{\circ}\text{C}$ .



# INSTALLATION INSTRUCTIONS

## Installation diagrams

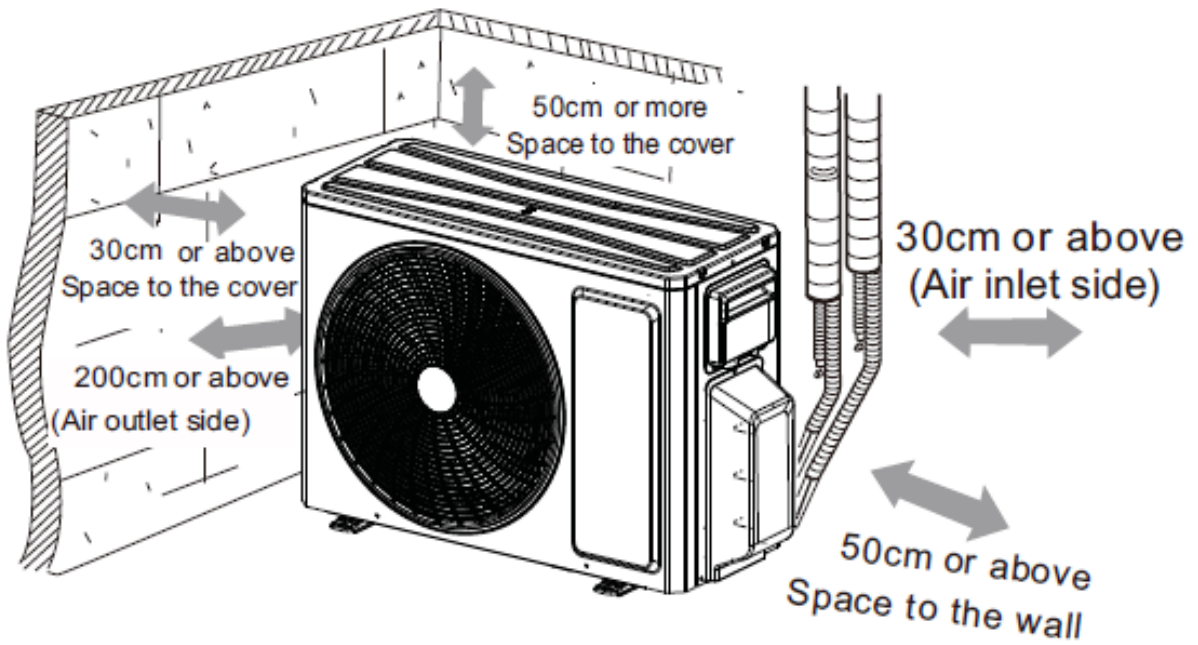

## INSTALLATION WARNINGS

**WARNING:** Make sure that the power supply is disconnected before carrying out any work on the unit.

**WARNING:** Wear appropriate personal protective equipment before carrying out any work on the unit.

**WARNING:** The appliance must be reinstalled in accordance with national system regulations.

**WARNING:** Wiring and installation must only be performed by a qualified technician trained to install, modify, extend and service the unit and perform safety and functionality tests.

**WARNING:** Install a device, master switch or electric plug that will allow all the power from the appliance to be switched off.

**WARNING:** Use only copper pipes for refrigerant connections.

**WARNING:** For the connection between the units, use only annealed and deoxidized copper pipe for conditioning and refrigeration and insulated with expanded polyethylene of min. 8 mm.

The following information is essential for correct unit installation. However, the installer should use his or her experience to install the unit according to specific requirements.

- Do not install the unit in locations where there are flammable gases or acid or alkaline substances that may irreparably damage the copper-aluminium heat exchangers or internal plastic components.
- Do not install the unit in offices or kitchens where oil vapours mixed with treated air may settle on the exchange coils, reducing performance, or on the unit's internal parts, damaging the plastic components. When installing or relocating the unit, be sure to keep the refrigerant circuit free of air or substances other than the specified refrigerant.
- Any presence of air or other foreign matter in the refrigerant circuit will cause increased system pressure or compressor failure, resulting in damage.
- When installing or relocating the unit, do not charge refrigerant that does not conform to that indicated on the nameplate or unidentified refrigerant. Otherwise, it may cause abnormal operation or an accident.
- When refrigerant needs to be recovered, in case of transfer or repair of the unit, make sure the unit is operating in cooling mode. Then, completely close the valve on the high pressure side (liquid valve). Approximately 30-40 seconds later, completely close the valve on the low pressure side (gas valve), stop the unit immediately and disconnect the power supply. The time for refrigerant recovery should not exceed 1 minute.
- If refrigerant recovery takes too long, air can be sucked in and cause pressure increase or compressor failure, resulting in injury.
- During refrigerant recovery, ensure that the liquid valve and gas valve are completely closed and the power supply is disconnected before disconnecting the connecting pipe.
- If the compressor starts to operate when the shut-off valve is open and the connecting pipe is not connected, the air will be drawn in and will cause the pressure to rise or the compressor to break, resulting in injury.
- When installing the unit, make sure that the connecting pipe is firmly connected before the compressor starts to run.
- Prohibit installation of the unit where there may be a leak of corrosive gas or flammable gas.
- In case of gas leaks from the unit, explosions and other accidents may occur.
- Do not use extension cables for electrical connections. If the electric cable is not long enough, please contact an authorized local service center and ask for an appropriate electric cable.
- Inadequate wiring can cause electric shock or fire.

- Use the specified cable types for electrical connections between indoor and outdoor units. Securely lock the cables so that their terminals do not receive external stress.
- Electric cables with insufficient capacity, incorrect cable connections and insecure cable terminals may cause electric shock or fire.

## Choosing a location for installation

Essential requirements	Indoor unit
<p>Do not install the unit in the following locations. Otherwise, a fault may occur.</p> <ol style="list-style-type: none"> <li>1. Locations with extreme heat sources or flammable or explosive gases or vapours.</li> <li>2. Locations with high-frequency devices (e.g. welding machines, medical equipment).</li> <li>3. Locations close to coastal areas.</li> <li>4. Locations with oils or fumes in the air.</li> <li>5. Locations with sulphide gas.</li> <li>6. Other locations that have special conditions.</li> </ol> <p>Do not operate the unit in the immediate vicinity of laundrettes, bathtubs, showers or swimming pools.</p>	<ol style="list-style-type: none"> <li>1. There should be no obstructions near the air inlet or outlet.</li> <li>2. Choose a location where the condensate can drain out easily without causing a nuisance.</li> <li>3. Choose a convenient location to connect the outdoor unit to the power outlet.</li> <li>4. Choose a location out of the reach of children.</li> <li>5. The site should be strong and solid enough to support the weight of the indoor unit and prevent noise or vibration.</li> <li>6. The unit should be installed 2.5 m from the floor.</li> <li>7. Do not install the indoor unit directly above electrical equipment.</li> <li>8. Try to keep a certain distance from fluorescent lights.</li> </ol>
Outdoor unit	
<ol style="list-style-type: none"> <li>1. Choose a location where the noise and airflow produced by the outdoor unit will not annoy neighbours.</li> <li>2. The location should be well ventilated and dry; the outdoor unit must not be exposed to direct sunlight or strong winds.</li> <li>3. The site should be able to support the weight of the outdoor unit.</li> <li>4. Check that the installation complies with the requirements of the dimensional drawing for installation.</li> <li>5. Choose a location out of the reach of children and away from animals or plants. If this is not possible, install safety fencing.</li> </ol>	

## Electrical connection requirements

### Safety precautions

1. Electrical safety standards must be met when installing the unit.
2. Use a power supply circuit and circuit breaker that comply with local safety regulations.
3. Make sure that the power supply matches the requirements of the air conditioner. An unstable power supply or incorrect wiring may result in a fault. Install suitable power cables before switching on the air conditioner.
4. Correctly connect the live, neutral and earth wires to the power outlet.
5. Disconnect the power supply before carrying out any work on the electrical circuit or carrying out any safety work. For models with a plug, make sure the plug is easily accessible after installation.
6. Do not connect the power before installation is complete.
7. Do not use the appliance if the power cable or plug are damaged. If the power cable is damaged it must be replaced by the manufacturer, retailer or other qualified person to avoid a hazard.
8. Since the temperature of the cooling circuit is high, keep the interconnecting cable away from the copper pipe.
9. The unit must be installed in accordance with national wiring regulations.
10. Installation must only be performed by trained individuals in accordance with regulations.



The unit is charged with a slightly inflammable refrigerant, R32. Improper handling of this gas may expose people and materials to serious damage. More details on this refrigerant are given at the beginning of this manual.

## Earthing

1. The air conditioner is a Class I appliance. The unit must be earthed with an appropriate device by a qualified technician. Ensure the unit is always properly earthed. Otherwise electric shock may result.
2. The green-yellow wire of the air conditioner is the earthing wire and may not be used for other purposes.
3. The earth resistance must meet national standards for electrical safety.
4. The unit must be positioned so that the plug is accessible.
5. An all-pole isolating switch with a minimum contact gap of 3mm in each pole must be connected to the fixed cable.
6. Insert a switch with sufficient power and observe the following table. The air switch must include a magnetic and thermal function for protection against short circuits and overloads. (Warning: do not use only the fuse to protect the circuit).

Air conditioner	Air switch capacity
14-18K	16A
21-24-28K	25A
36K – 42K	32A

## ARGO DUAL 14 DCI R32 – ARGO DUAL 18 DCI R32

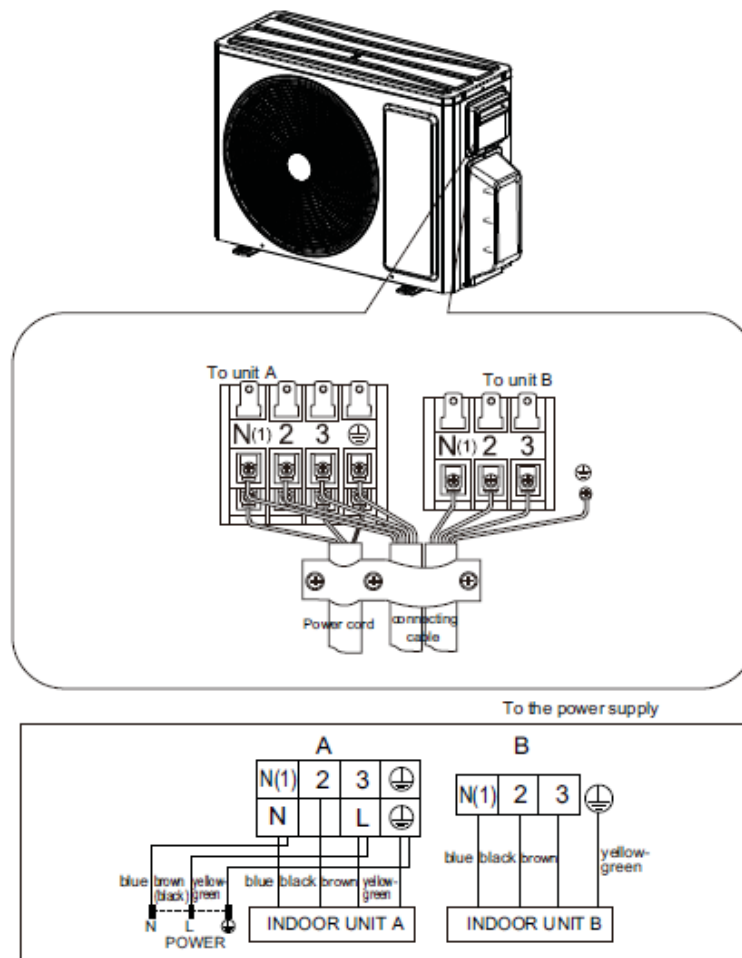

**ARGO TRIAL 21 DCI R32 – ARGO TRIAL 24 DCI R32**

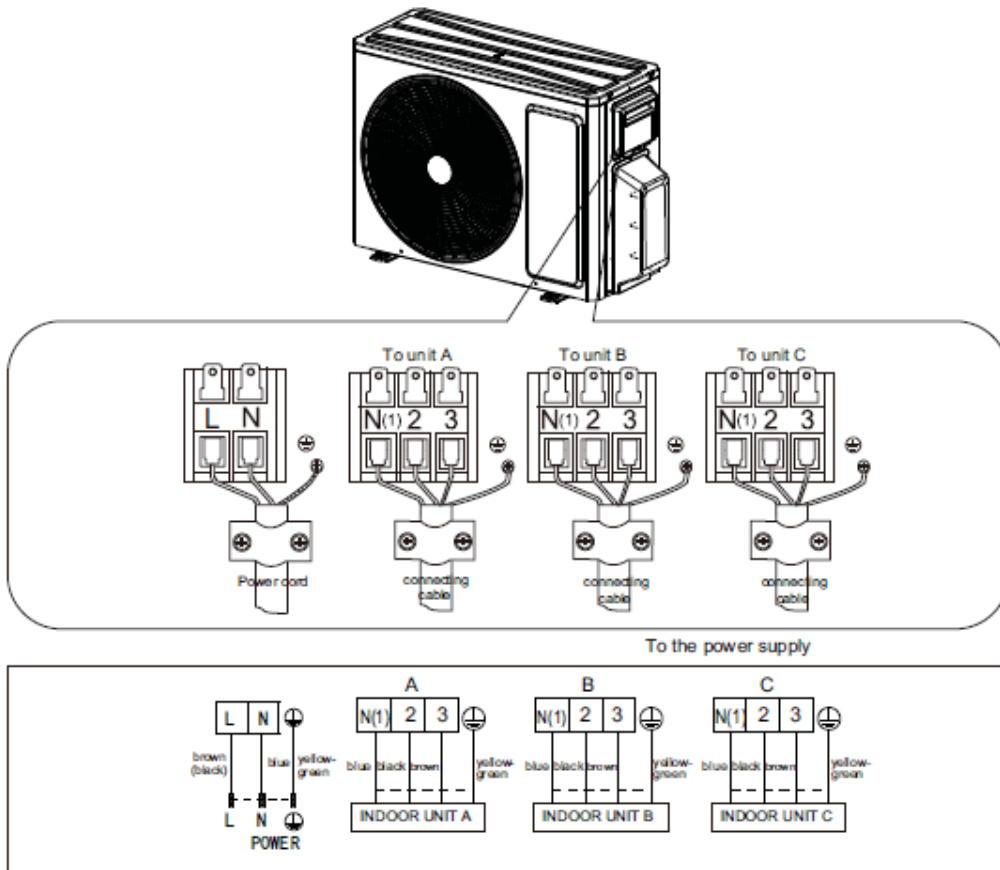

**ARGO QUADRI 28 DCI R32 – ARGO QUADRI 36 DCI R32**

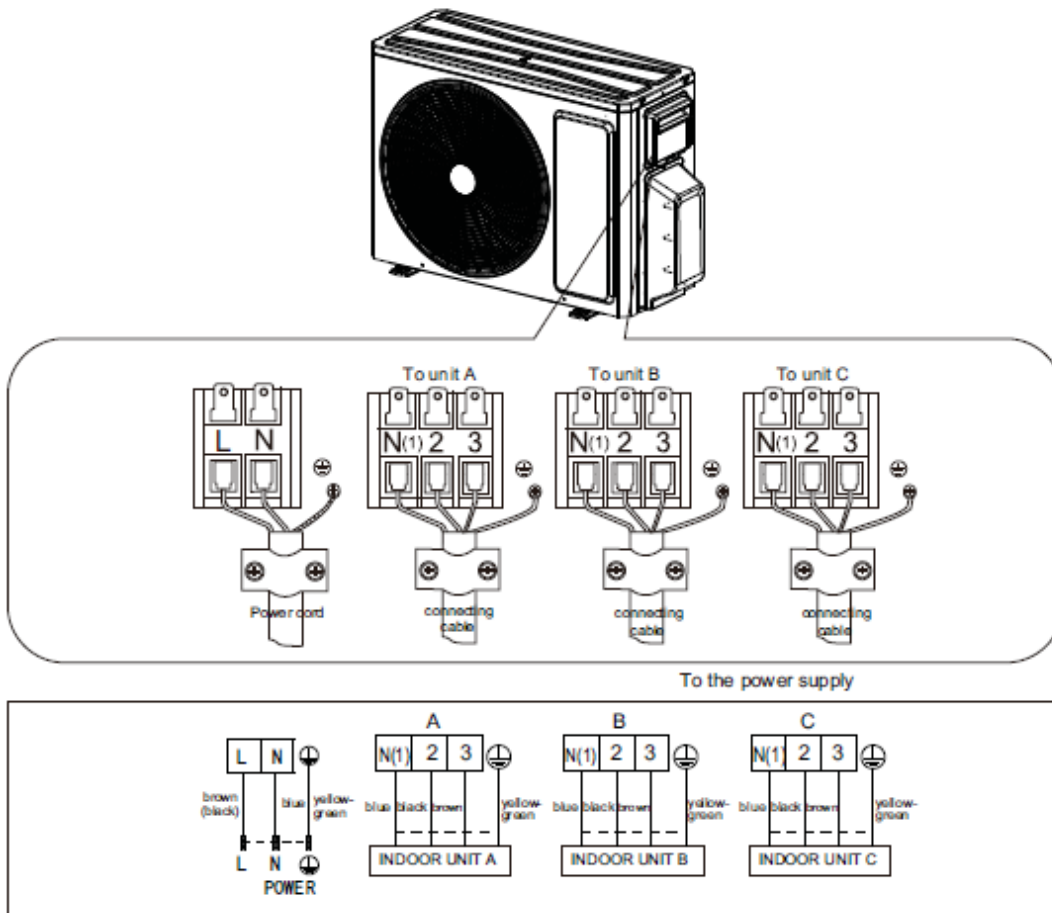

## ARGO PENTA 42 DCI R32

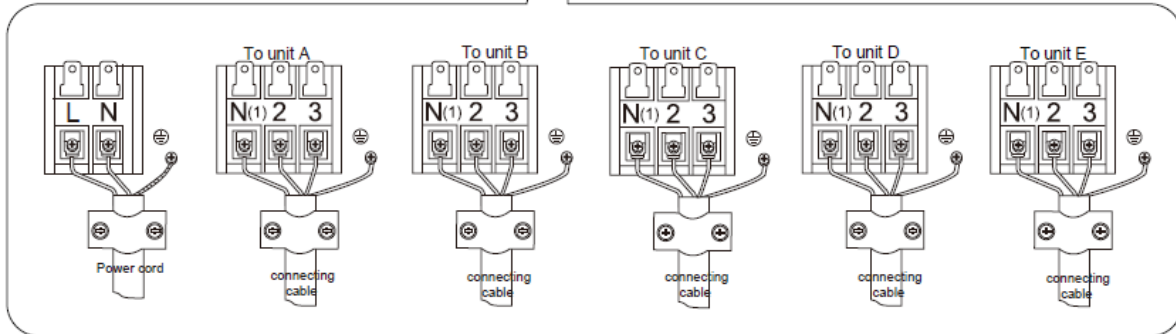
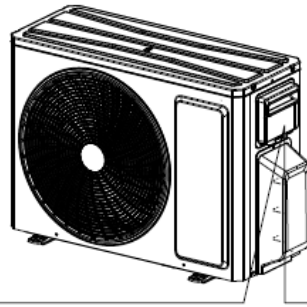

To the power supply

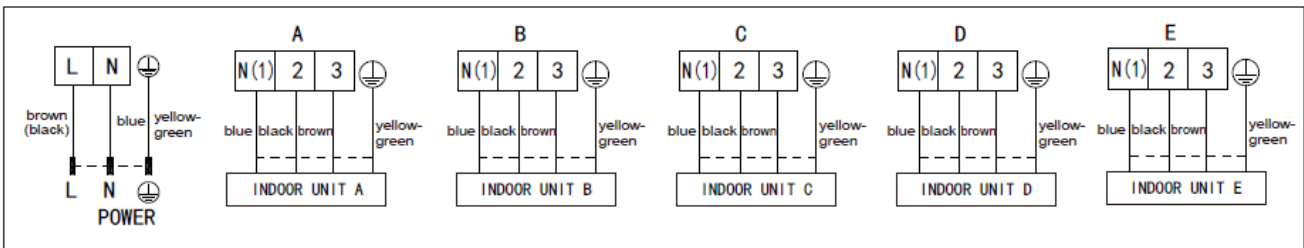

## Outdoor unit installation

For all connections refer to the wiring diagrams supplied with the unit. If the outdoor unit was connected to a higher level than the one of the indoor unit, you must make a siphon. The outdoor unit must be installed outdoors, in a perfectly horizontal position, respecting the minimum distances to allow the air to flow and the execution of any maintenance. The unit is built with resistant materials to protect it from any weather condition so it's not necessary to protect it in a particular way. Make sure however that the heat exchanger is not exposed to the danger of hail. If you want to attach the unit to a wall, use brackets appropriately sized to support the weight of the unit. Condensation produced due to the operation in heating can be piped to a drain using the appropriate predisposition.

### Fix the outdoor unit support

1. Choose the location of the system based on the structure of the house.
2. Fix the support of the outdoor unit in the chosen position with expansion screws.

**Note:**

- Take sufficient protective measures when installing the outdoor unit.
- Make sure that the stand can support at least four times the weight of the unit.
- The outdoor unit must be placed at least 3cm above the floor in order to install the drain joint.
- For the unit with refrigerant capacity of 2300W ~ 5000W, 6 expansion screws are required; 8 expansion screws are required for the unit with 6000W ~ 8000W cooling capacity; For the unit with refrigerant capacity of 10000W ~ 16000W, 10 expansion screws are required.

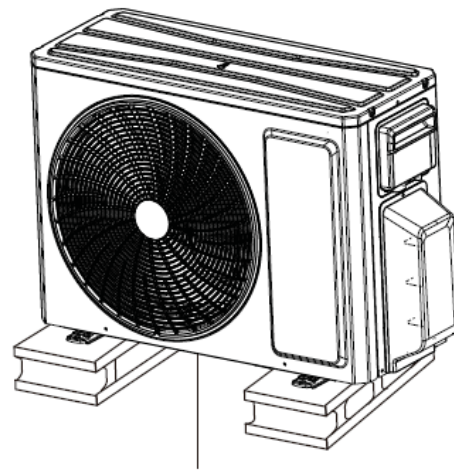

at least 3cm above the floor

## Vacuum pump

### Use the vacuum pump

Humid air left inside the refrigerant circuit can cause compressor malfunction. After having connected the indoor and outdoor units, bleed the air and humidity from the refrigerant circuit using a vacuum pump.

- (1) Unscrew and remove the caps from the 2-way and 3-way valves.
- (2) Unscrew and remove the cap from the service valve.
- (3) Connect the vacuum pump hose to the service valve.
- (4) Operate the vacuum pump for 10-15 minutes until an low-pressure knob on the vacuum pump coupling. absolute vacuum of 10 mm Hg has been reached.
- (5) With the vacuum pump still in operation, close the Stop the vacuum pump.
- (6) Open the 2-way valve by 1/4 turn and then close it after 10 seconds. Check all the joints for leaks using liquid soap or an electronic leak device.

Vacuum pump

Vacuum pump Location

- (7) Turn the body of the 2-way and 3-way valves. Disconnect the vacuum pump hose.
- (8) Replace and tighten all the caps on the valves.

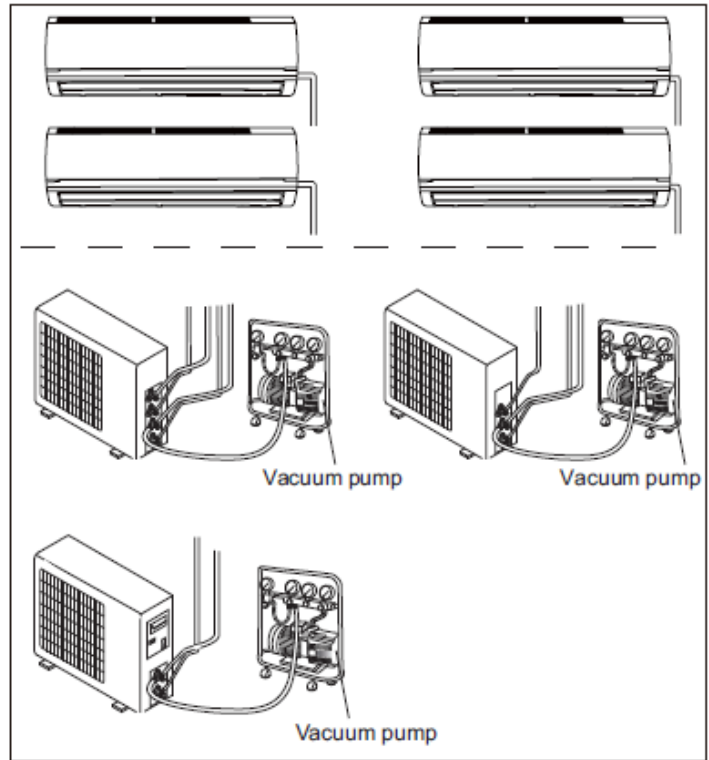

Diameter (mm)	Twisting moment (N.m)
1/4"	15-20
3/8"	35-40
1/2"	45-50
5/8"	60-65
3/4"	70-75

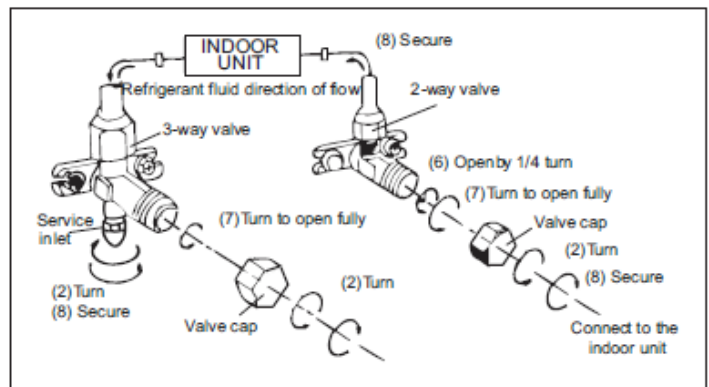



## Leakage detection

1. With leakage detector: Check if there is leakage with leakage detector.
2. With soap water: If leakage detector is not available, please use soap water for leakage detection. Apply soap water at the suspected position and keep the soap water for more than 3min. If there are air bubbles coming out of this position, there's a leakage.

## Install the drain fitting and the drain hose

Use bolts to secure the unit to a flat, solid floor. **(for model with heat pump only)**

Condensation is produced and flows from the outdoor unit when the appliance is operating in the heating mode. In order not to disturb neighbors and to respect the environment, install a drain fitting and a drain hose to channel the condensate water. Install the drain fitting and rubber washer on the outdoor unit chassis and connect a drain hose to it as shown in the figure.

The refrigerant pipes must not exceed the maximum heights 15m.

The sum of the capacity codes of the indoor units should be among 50%-150% of that of the outdoor unit.

**NOTE:** As for the shape of drainage joint, please refer to the current product. Do not install the drainage joint in the severe cold area. Otherwise, it will be frosted and then cause malfunction.

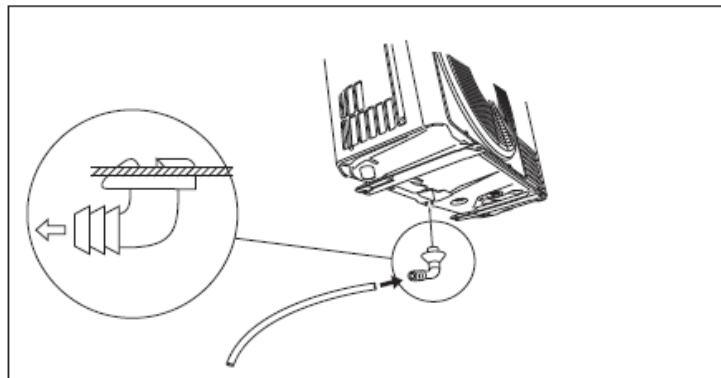

## Post-installation checks

Checks	Possible fault
Has the unit been installed securely?	The unit could fall, move or produce excessive noise.
Is the thermal insulation of the pipes sufficient?	Risk of condensation and dripping water.



Has the check for gas leaks been executed?	Risk of cooling (heating) not satisfactory.
Does the water drain properly?	Risk of condensation and dripping water.
Does the supply voltage match the voltage indicated on the data plate?	Risk of malfunction or damage to components.
Have the piping and electrical wiring been installed correctly?	Risk of malfunction or damage to components.
Has the unit been properly earthed?	Risk of electric leakage.
Does the power cable meet requirements?	Risk of malfunction or damage to components.
Are there any obstructions at the air inlet or outlet?	The cooling (heating) capacity may be insufficient.
Have the dust and other particles produced during installation been removed?	Risk of malfunction or damage to components.
Are the gas valve and liquid valve of the connecting tube fully open?	The cooling (heating) capacity may be insufficient.
Have the length of the refrigerating tube and the amount of the refrigerant charge been registered?	It is not easy to decide the amount of the refrigerant charge to add.

## Safety operation of flammable refrigerant

### Qualification requirement for installation and maintenance

- All workers who engage with the refrigeration system should bear the valid certification awarded by the authoritative organization, and the qualification recognized by the industry for dealing with the refrigeration system.
- The refrigeration system can only be repaired following the methods suggested by the equipment's manufacturer.

### Installation notes

- The air conditioner mustn't be used in a room that has running fire or heat sources (such as, working coal gas ware, operating heater).
- Do not drill holes in the circuit or burn the connection pipe.
- The air conditioner must be installed in a room that is larger than the minimum room area. The minimum room area is shown on the following "table a".
- Leak test is mandatory after installation.

table a - Minimum room area ( m<sup>2</sup> )

Minimum room area( m <sup>2</sup> )	Charge amount (kg)	≤1.2	1.3	1.4	1.5	1.6	1.7	1.8	1.9	2	2.1	2.2	2.3	2.4	2.5
	floor location	/	14.5	16.8	19.3	22	24.8	27.8	31	34.3	37.8	41.5	45.4	49.4	53.6
window mounted	/	5.2	6.1	7	7.9	8.9	10	11.2	12.4	13.6	15	16.3	17.8	19.3	
wall mounted	/	1.6	1.9	2.1	2.4	2.8	3.1	3.4	3.8	4.2	4.6	5	5.5	6	
ceiling mounted	/	1.1	1.3	1.4	1.6	1.8	2.1	2.3	2.6	2.8	3.1	3.4	3.7	4	

## Maintenance notes

- Check whether the maintenance area or the room area meet the requirement of “table a”- the unit is only allowed to be operated in rooms that meet these requirements.
- Check whether the maintenance area is well-ventilated. - The continuous ventilation status should be kept during the entire operation process.
- Check whether there is a fire source or potential fire source in the maintenance area. Running fire is prohibited in the maintenance area and the “no smoking” sign should be hanged.
- Check whether the warning sign is in good condition, otherwise replace it.

## Welding

- If it is necessary to cut or weld the refrigerant system pipes in the maintenance procedures, please follow the steps here below:
  - a. Shut down the unit and cut power supply
  - b. Eliminate the refrigerant
  - c. Vacuum with a vacuum machine
  - d. Clean the pipes with the N2 gas
  - e. Cut and weld or
  - f. Bring the unit to a service centre for welding
- The refrigerant should be recycled in a specialized storage tank.
- Make sure there aren't any free flames near the outlet of the vacuum pump and that it's well-ventilated.

## Filling the refrigerator circuit

- Use refrigerant filling appliances specialized for R32. Make sure that different kinds of refrigerant don't contaminate one another.
- The refrigerant tank should be kept upright when filling with the refrigerant.
- Stick the label on the system after filling is finished.
- Don't overfill.
- After filling is finished, please test the unit for leakage detection before the operation test; another test for leakage detection should be carried out when the refrigerant is removed.

## Safety instructions for transportation and storage

- Please use a flammable gas detector to check before unloading and opening the container.
- No fire source and no-smoking.
- According to the local rules and laws

## TESTING AND OPERATION

### Test operation

#### Preparation of test operation

- The client approves the air conditioner.
- Specify the important notes for air conditioner to the client.

#### Method of test operation

- Put through the power, press ON/OFF button on the remote controller to start operation.
- Press MODE button to select AUTO, COOL, DRY, FAN and HEAT to check whether the operation is normal or not.
- If the ambient temperature is lower than 16°C, the air conditioner can't start cooling.

# APPENDIX

## Configuration of connection pipe

1. Standard length of connection pipe: 5m, 7.5m, 8m.
2. Min. length of connection pipe.

For the unit with standard connection pipe of 5m, there is no limitation for the min length of connection pipe. For the unit with standard connection pipe of 7.5m and 8m, the min length of connection pipe is 3m.

Max. length of connection pipe is shown as below:

Models	14-18K	21-24K	28K	36K	42K
Max length of connection pipe	40	60	70	80	100
Max length of connection pipe (simple one indoor unit)	20	20	20	25	25
Max height between indoor and outdoor unit	15	15	15	25	25

1. Method to calculate the additional charge amount of oil and refrigerant with the extended connection pipe: if the length of the connection pipe is increased by 10m compared to the standard length, add 5ml of refrigerant oil for every 5m of pipe added.

Method for calculating the amount of additional refrigerant charge (liquid pipe):

1. amount of additional refrigerant charge = additional length of liquid pipe x additional amount of refrigerant charge per meter.
2. Based on the standard pipe length, add the refrigerant according to the requirement shown in the table above

Method to calculate the amount of additional refrigerant charge (liquid pipe): amount of additional refrigerant charge = additional length of liquid pipe x additional amount of refrigerant charge per meter.

**Always write the additional refrigerant charge on the data label affixed to the unit outside.**

	Diameter of external unit taps.		Additional refrigerant charge R32
	Liquid pipe (mm)	Gas pipe (mm)	(g/m)
9-12K	Φ6,35	Φ9,52	16

## Procedure for extending the piping

**N.B.:**

Improper extension of piping is the main cause of refrigerant leaks. Proceed as shown below:

### 1. Cut the pipe

- Check the length of the pipe based on the distance between the indoor unit and outdoor unit.
- Cut the required pipe using a pipe cutter.

### 5. Expand the port

Expand the port using a pipe expander.

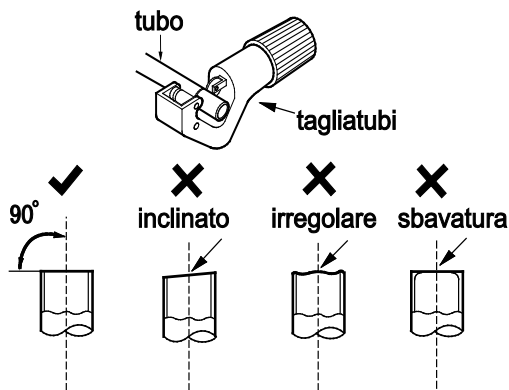

tubo	pipe
tagliatubi	pipe cutter
inclinato	slanted
irregolare	uneven
sbavatura	burred

## 2. Remove burrs

- Remove burrs with a file, ensuring they do not go into the pipe.

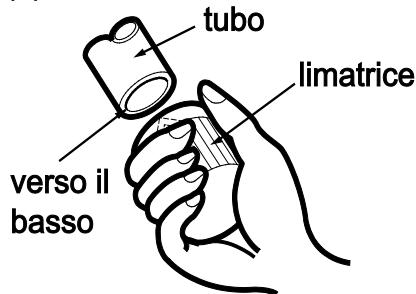

tubo	pipe
limatrice	file
verso il basso	downwards

## 3. Secure an insulating tube

### 4. Install a union nut

- Remove the union nut on the indoor connecting pipe and outdoor valve. Install the union nut on the pipe.



tubo di raccordo	union pipe
tubo	pipe

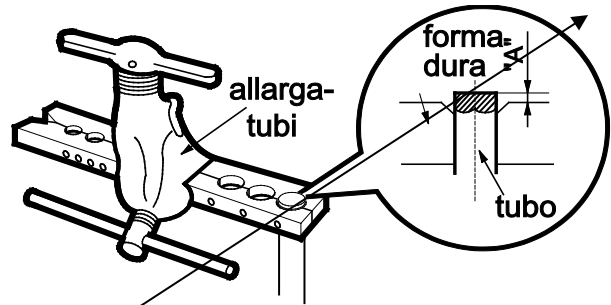

allargatubi	pipe expander
forma dura	hard mould
tubo	pipe

N.B.:

- "A" varies according to diameter:

Outdoor diameter (mm)	A (mm)	
	Max.	Min.
6.35 (1/4")	1.3	0.7
9.52 (3/8")	1.6	1.0

## 6. Inspection

Check the quality of the expanded port. If defective, expand the port again following the procedure described above.

superficie liscia

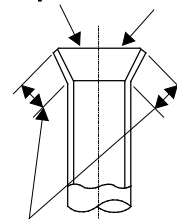

allargamento imperfetto



lunghezza uguale

superficie liscia	smooth surface
allargamento imperfetto	defective expansion
lunghezza uguale	equal length
inclinato	slanted
superficie danneggiata	surface damaged
fessurazione	cracked
spessore irregolare	uneven thickness

# Warnings for the refrigeration system specialist

Here are warnings and safety instructions for the maintenance of systems containing flammable refrigerant (repairs should only be carried out by specialists).

a) Any person involved in the work or in the interruption of a refrigeration circuit must be equipped with PEF (European Refrigerators License) as required by the D.P.R. n. 146/2018 implementing Regulation (EU) no. 517/2014.

b) Maintenance should only be performed as recommended by the equipment manufacturer. Maintenance and repairs that require the assistance of other qualified personnel must be performed under the supervision of the person competent in the use of flammable refrigerants.

Before starting work on systems containing flammable refrigerants, safety checks are required to ensure that the risk of ignition is minimized.

c) Checks to be carried out on systems that use flammable refrigerants:

- the charge must be proportionate to the size of the room in which the units containing refrigerant are installed;
- units and ventilation openings must function properly and are not obstructed;
- if an indirect refrigerant circuit is used, the secondary circuit must be checked for the presence of refrigerant;
- the marking on the equipment must be visible and indelible. Illegible markings and signs must be corrected;
- refrigerant piping or components must be installed in a location where they are unlikely to be exposed to any substance that can corrode the component-containing refrigerant, unless the components are constructed from materials that are inherently resistant to corrosion or are adequately protected against corrosion.

d) Checks on electrical devices

Repair and maintenance of electrical components must include initial safety checks and component inspection procedures. If there is a fault that could compromise safety, do not connect the power supply to the circuit until it is satisfactorily resolved. If the fault cannot be remedied immediately, but operation must continue, a suitable interim solution must be used. This must be reported to the owner of the equipment so that all parties are informed.

Initial security checks include:

- Check that the capacitors are discharged: this must be done safely to avoid the risk of sparks;
- Verify that no electrical components and wiring are exposed while charging, restoring or draining the system;
- Check that there is ground continuity.

e) Check for refrigerant leaks

The area should be checked with an appropriate refrigerant detector before and during work, to ensure that the technician is aware of potentially toxic or flammable atmospheres. Make sure that the leak detection equipment in use is suitable for use with all applicable refrigerants, i.e. non-sparking, properly sealed or intrinsically safe.

Check for R32 refrigerant leaks

Note: Check for refrigerant leakage in an environment where there are no potential sources of ignition. No halogen probe (or any other detector that uses an open flame) should be used.

Leak Detection Method:

For systems with R32 refrigerant, an electronic leak detection tool is available to detect and leak detection should not be conducted in a refrigerant environment. Make sure the leak detector does not become a potential source of ignition and is applicable to the measured refrigerant. The leak detector must be set for the minimum flammable fuel concentration (percentage) of the refrigerant. Calibrate and adjust to the correct gas concentration (no more than 25%) with the refrigerant used.

The fluid used in leak detection is applicable to most refrigerants. But do not use chloride based solvents to prevent the reaction between chlorine and refrigerants and corrosion of copper piping.

If you suspect a leak, remove all fire from the scene or put out the fire.

If the location of the leak is to be welded, then all refrigerants must be recovered or isolate all refrigerants away from the leak site (using the shut-off valve). Before and during soldering, use OFN to purify the entire system.

f) Presence of fire extinguisher

If hot work is to be performed on the refrigeration equipment or any associated part, adequate fire fighting equipment must be available. It is necessary to have a dry powder or CO<sub>2</sub> extinguisher adjacent to the charging area.

g) Ventilated area

Make sure the area is outdoors or is adequately ventilated before breaking into the system or performing any hot work. Continuous ventilation must be present during the period in which the work is being carried out. Ventilation should safely disperse the released refrigerant and preferably expel it to the atmosphere.

h) Controls on refrigeration equipment

When replacing electrical components, they must be fit for purpose and with the correct specifications. The manufacturer's maintenance and service guidelines should always be followed. If in doubt, consult the manufacturer's technical department for assistance.

i) Repairs on sealed components

During repairs to sealed components, all electrical supplies must be disconnected from the equipment being worked on before removing the sealed covers, etc.

If it is absolutely necessary to have an electrical power supply to the equipment during maintenance, then a leak detection device must be placed at the most critical point to warn of a potentially dangerous situation.

Particular attention must be paid to the following to ensure that, by working on the electrical components, the casing is not altered in such a way as to compromise the level of protection. This includes damage to cables, excessive number of connections, terminals not made to original specifications, damage to gaskets, incorrect assembly of cable glands, etc.

- Make sure the appliance is mounted securely.
- Ensure that gaskets or sealing materials are not degraded to the point that they no longer serve the purpose of preventing the entry of flammable atmospheres. Replacement parts must conform to the manufacturer's specifications.

NOTE: The use of silicone sealant can inhibit the effectiveness of some types of leak detection equipment. Intrinsically safe components do not need to be isolated before working on them.

l) Repair of intrinsically safe components

Do not apply permanent inductive or capacitive loads to the circuit without ensuring that it does not exceed the voltage and current allowed for the equipment in use.

The intrinsically safe components are the only ones that can be worked on in the presence of a flammable atmosphere. The test equipment must be of the correct evaluation.

Replace components only with parts specified by the manufacturer. Other parts can cause the refrigerant to ignite in the atmosphere due to a leak.

j) Wiring

Verify that the wiring is not subject to wear, corrosion, excessive pressure, vibration, sharp edges, or other adverse environmental effects.

The control must also take into account the effects of aging or continuous vibrations from sources such as compressors or fans.

k) Deactivation

Before carrying out this procedure, it is essential that the technician is fully familiar with the equipment and all its details. Good practice is recommended that all refrigerants be recovered safely. Before the task is performed, a sample of the oil and

refrigerant must be taken in case an analysis is required before reuse of the recovered refrigerant. It is essential that electricity is available before the start of the activity.

A. Become familiar with the equipment and its operation.

B. Electrically isolate the system.

C. Before attempting the procedure, make sure that:

- mechanical handling equipment is available, if required, for handling the refrigerant cylinders;
- all personal protective equipment is available and used correctly;
- the recovery process is supervised at all times by a competent person;
- Recovery equipment and cylinders comply with appropriate standards.

D. If possible, drain the refrigerant system.

E. If vacuum is not possible, make a manifold so that the refrigerant can be removed from the various parts of the system.

F. Make sure the cylinder is placed on the scale before recovery takes place.

G. Start the recovery machine and operate according to the manufacturer's instructions

H. Do not overfill the cylinders. (Not more than 80% by volume of liquid charge).

I. Do not exceed, even temporarily, the maximum working pressure of the cylinder.

J. When the cylinders have been filled correctly and the process is complete, ensure that the cylinders and equipment are promptly removed from the site and that all isolation valves on the equipment are closed.

K. Recovered refrigerant should not be charged to another refrigeration system unless it has been cleaned and checked.

#### I) Labeling

The equipment must be labeled indicating that it has been shut down and drained of refrigerant. The label must be dated and signed. For appliances containing flammable refrigerants, make sure there are labels on the appliance indicating that the appliance contains flammable refrigerant.

#### Recovery

When removing refrigerant from a system, whether for maintenance or decommissioning,

It is recommended that all refrigerants be removed safely.

When transferring refrigerant to cylinders, ensure that only appropriate refrigerant recovery cylinders are used. Make sure the correct number of cylinders are available to maintain full system charge. All cylinders to be used are designated for the recovered refrigerant and labeled for that refrigerant (i.e. special cylinders for recovering refrigerant). The cylinders must be complete with pressure relief valve and relative shut-off valves in good working order. Empty recovery cylinders are evacuated and, if possible, cooled before recovery takes place.

If compressors or compressor oils need to be removed, make sure they have been evacuated to an acceptable level to ensure that flammable refrigerant does not remain within the lubricant. The evacuation process must be carried out before returning the compressor to suppliers. To speed up this process, only electrical heating of the compressor body must be used. When oil is drained from a system, it must be done safely

#### Work procedure

The work must be carried out according to a controlled procedure in order to minimize the risk of the presence of flammable gas or vapor during the execution of the work.

##### 2. General work area

All maintenance personnel and others working in the local area should be educated on the nature of the work being performed. Work in confined spaces must be avoided. The area around the work area must be sectioned. Ensure that conditions within the area have been secured by the control of flammable material.

##### 3. No ignition sources

No person carrying out work in relation to a refrigeration system involving exposure to piping must use sources of ignition in a way that creates the risk of fire or explosion. All possible sources of ignition, including cigarette smoke, must be kept sufficiently far from the place of installation, repair, removal and disposal, during which the refrigerant may possibly be

released into the surrounding space. Before starting work, the area around the equipment must be checked to ensure that there is no risk of flammability or ignition hazards. "No smoking" signs must be displayed.

#### Removal and evacuation

When breaking into the refrigerant circuit to make repairs or for any other purpose, conventional procedures must be used. However, for flammable refrigerants it is important to follow the best procedures as there is a risk of flammability.

The following procedure must be followed:

- remove the refrigerant;
- purge the circuit with inert gas; evacuate;
- purge again with inert gas;
- open the circuit by cutting or brazing.

The refrigerant charge must be recovered in the correct recovery cylinders.

For appliances containing flammable refrigerants, the system must be flushed with OFN to make the unit safe. You may need to repeat this process several times. Compressed air or oxygen must not be used for purging refrigerant systems.

For appliances containing flammable refrigerants, flushing must be achieved by breaking the vacuum in the system with OFN and continuing to fill until the operating pressure is reached, then discharging to the atmosphere and finally lowering the vacuum. This process must be repeated until there is no more refrigerant in the system. When the final OFN charge is used, the system must be vented to atmospheric pressure to allow the work to be carried out. This operation is absolutely essential if you want to carry out brazing operations on the pipes.

Make sure that the vacuum pump outlet is not close to ignition sources and that ventilation is available.

#### Charging procedures

In addition to conventional charging procedures, the following requirements must be followed.

- Make sure that contamination of different refrigerants does not occur when using charging equipment. Hoses or lines should be as short as possible to minimize the amount of refrigerant they contain.
- The cylinders must be kept upright.
- Make sure the refrigeration system is grounded before charging the system with refrigerant.
- Label the system when charging is complete (if not already done).
- Be very careful not to overfill the refrigeration system.

Before recharging the system, it must be pressure tested with the appropriate purge gas.

The system must undergo a leak test upon completion of the charge but prior to commissioning. A subsequent leak test must be carried out before leaving the site.



**REGULATION (EU) No. 517/2014 - F-GAS**

The unit contains R32, a fluorinated greenhouse gas with global warming potential (GWP) = 675.

Do not release R32 into the atmosphere.

**DUAL 14 DCI R32 - Kg. 0,75 = Tonn CO<sub>2</sub> equiv. 0,51**

**DUAL 18 DCI R32 - Kg. 0,90 = Tonn CO<sub>2</sub> equiv. 0,61**

**TRIAL 21 DCI R32 - Kg. 1,60 = Tonn CO<sub>2</sub> equiv. 1,08**

**TRIAL 24 DCI R32 - Kg. 1,70 = Tonn CO<sub>2</sub> equiv. 1,147**

**QUADRI 28 DCI R32 - Kg. 1,80 = Tonn CO<sub>2</sub> equiv. 1,215**

**QUADRI 36 DCI R32 - Kg. 2,40 = Tonn CO<sub>2</sub> equiv. 1,62**

**PENTA 42 DCI R32 - Kg. 2,40 = Tonn CO<sub>2</sub> equiv. 1,62**



improve your life

[www.argoclima.com](http://www.argoclima.com)